

TOSHIBA

FILE NO. 020-200506

SERVICE MANUAL

Projection Television

52HM85
62HM85

TABLE OF CONTENTS

SAFETY INSTRUCTIONS	3
SERVICE MODE	4
SETTING & ADJUSTING DATA	7
LAMP UNIT REPLACEMENT	8
LIGHT ENGINE REPLACEMENT	11
PARTS REPLACEMENT IN LIGHT ENGINE	13
EXPLODED VIEW	15
MECHANICAL DISASSEMBLY	16
CHASSIS REPLACEMENT PARTS LIST	17
PC BOARDS TOP AND BOTTOM VIEW	24
TERMINAL VIEW OF TRANSISTORS	36
CIRCUIT BLOCK DIAGRAM	39
APPENDIX:	
CIRCUIT DIAGRAM	

SAFETY INSTRUCTIONS

SAFETY PRECAUTION

WARNING: Service should not be attempted by anyone unfamiliar with the necessary precautions on this receiver. The following are the necessary precautions to be observed before servicing this chassis.

1. An isolation transformer should be connected in the power line between the receiver and the AC line before any service is performed on the receiver.
2. When replacing a chassis in the cabinet, always be certain that all the prospective devices are put back in place, such as; non-metallic control knobs, insulating covers, shields, isolation resistor-capacitor network etc.

PRODUCT SAFETY NOTICE

Many electrical and mechanical parts in this chassis have special safety-related characteristics. These characteristics are often passed unnoticed by a visual inspection and the protection afforded by them cannot necessarily be obtained by using replacement components rated for higher voltage, wattage, etc. Replacement parts which have these special safety characteristics are identified in this manual and its supplements; electrical components having such features are identified by the international hazard symbols on the schematic diagram and the parts list.

Before replacing any of these components, read the parts list in this manual carefully. The use of substitute replacement parts which do not have the same safety characteristics as specified in the parts list may create shock, fire, or other hazards.

SERVICE MODE

1. ENTERING SERVICE MODE

- 1) Press MUTE button twice on Remote Control.
- 2) Press MUTE button again and keep pressing.
- 3) While pressing the MUTE button, press MENU button on TV set.

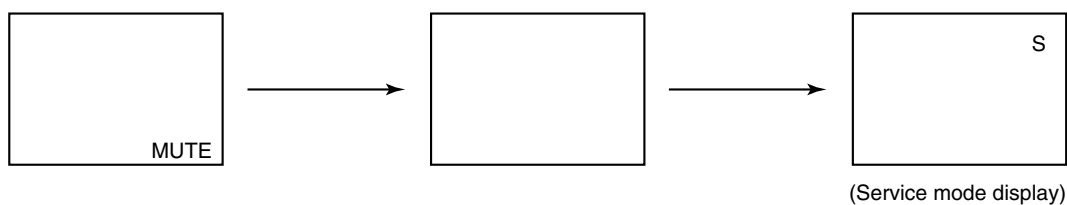

2. DISPLAYING THE ADJUSTMENT MENU

- 1) Press MENU button on TV.

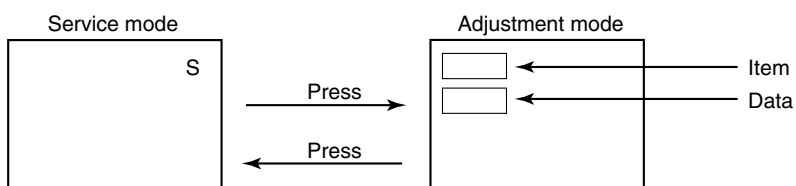

3. SELECTING THE ADJUSTING ITEMS

- 1) Every pressing of CHANNEL ▲ button in the service mode changes the adjustment items in the order of table-2. (▼ button for reverse order)

Refer to table-1 for preset data of adjustment mode.
(See SETTING & ADJUSTING DATA on page 7)

4. ADJUSTING THE DATA

- 1) Pressing of VOLUME ▲ or ▼ button will change the value of data in the range from 00H to FFH. The variable range depends on the adjusting item.

5. EXIT FROM SERVICE MODE

- 1) Pressing POWER button to turn off the TV once.

7. LED indications

The green and red LED lights on the TV control touchpad (on the lower right corner of the TV screen) indicate the TV's current status, as follows:

- Green ON Solid (not blinking) = Control touchpad being pressed.
- Red ON Solid (not blinking) = Power ON.
- Green and/or Red blinking (see table below for condition and solution).

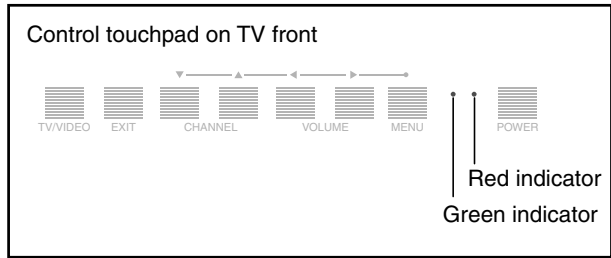

	LED Indication	Condition	Solution
1	Red and Green turn off.	Power supply OFF. (AC)	
2	Red and Green turn off.	Power supply OFF. (Standby) (North America)	
3	Red light solid and Green off.	Power supply ON.	
4	Red and Green lights solid.	Touched the touchpad	
5	Green blinks at 1-second intervals; Red off.	Lamp LPS mode	
6	Green blinks at 0.3-second intervals; Red lights solid.	The lamp is not working properly.	The TV automatically will try to restart itself eight times.
7	Green lights solid and Red blinks at 0.5-second intervals.	The lamp unit door is not seated properly. (U)	Turn the POWER OFF and unplug the power cord. Review "Lamp Unit Replacement" on pages 8-10 to ensure that the lamp unit door is installed securely.
8	Green and Red blink at 1-second intervals.	The lamp is not working properly after the eight automatic restart (see item #7). (U)	Turn the POWER OFF and then ON again. If the problem persists, replace the lamp unit (see pages 8-10).
9	Red blinks at 0.5-second intervals; Green off.	FAN (Light engine unit) has stopped.	<ul style="list-style-type: none"> • Is the output voltage of the supply voltage regulator for the FAN in the power circuit normal? • Has dust accumulated in the FAN? → If the output voltage is not abnormal, replace the faulty FAN with a new one.
10	Red blinks at 1-second intervals; Green off.	BUS line is damaged	<ul style="list-style-type: none"> • Check the faulty device through the self diagnostics function under SERVICE mode. • Does BUS line (SCL, SDA) work normally? → If the BUS line is under abnormal conditions, replace the faulty device with a new one.
11	Red blinks three times; Green off.	The color wheel has stopped.	<ul style="list-style-type: none"> • Is the output voltage of the power supply circuit normal? → If the output voltage is normal, replace the engine with a new one.
12	Red and Green blink three times.	Temperature rises abnormally.	<ul style="list-style-type: none"> • Is the ventilating hole in the set (exhaust slot on the rear) blocked or covered? • Is FAN rotating normally? • Has dust accumulated in the ventilating hole? → If no abnormally conditions are found, replace the engine with a new one.

(U) is restoration by the user.

SETTING & ADJUSTING DATA

【 SERVICE MODE 】

ADJUSTING ITEMS AND DATA IN THE SERVICE MODE:

Item	Name of adjustment	Preset	Data	Item	Name of adjustment	Preset	Data
RCUT	R CUT OFF	60H	←	OPT1	TV SET OPTION 1	A0H	←
GCUT	G CUTOFF	60H	←	TVOP	TV OPTION	40H	←
BCUT	B CUT OFF	64H	←	PLLW0	PLL WAIT TIME	14H	←
RDRV	R DRIVE	48H	←	PLLW1	PLL WAIT TIME	03H	←
GDRV	G DRIVE	53H	←	PLLW2	PLL WAIT TIME	0FH	←
BDRV	B DRIVE	5FH	←	PLLW3	PLL WAIT TIME	05H	←
BRTC	BRIGHT CENTER	76H	←	PLLW4	PLL WAIT TIME	14H	←
SCNT	SUB CONTRAST FOR TV	20H	←	PLLW5	PLL WAIT TIME	04H	←
COLC	COLOR CENTER	D0H	←	V01	VOLUME (DATA)	23H	←
UVTT	BASE BAND TINT	40H	←	V25	VOLUME (DATA)	4AH	←
CNTX	SUB CONTRAST MAX	7FH	←	V50	VOLUME (DATA)	63H	←
HPOS	H-POSITION (PAL/DFS)	00H	←	V75	VOLUME (DATA)	6FH	←
VPOS	V-POSITION DC SHIFT (PAL/DFS)	00H	←	V100	VOLUME (DATA)	73H	←
CWDH	COLOR WHEEL DELAY (HIGH)	00H	←	MODH	MODUS DATA HIGH	20H	←
CWDL	COLOR WHEEL DELAY (LOW)	FAH	←	MODL	MODUS DATA LOW	91H	←
DMDB	DMD BIAS	03H	←	PRES	FMAM PRESCALE	24H	←
OPT0	TV SET OPTION 0	00H	←	SCTH	VOLUME SCART OPTION HIGH	73H	←
				SCTL	VOLUME SCART OPTION LOW	01H	←

Table-1

Note:

The image system data of RCUT-CNTX is different by each image format.

The NTSC value is indicated in the table.

LAMP UNIT REPLACEMENT

Cautions when replacing LAMP UNIT (E998Z; PJ-D95-LMP)

The light source for this TV is a mercury lamp with internal atmospheric pressure that increases during use. The lamp has a limited service life that varies depending on user settings. If you use the lamp beyond its service life:

- you may notice a reduction in the colors and/or brightness of the picture; and
- the strength of the quartz glass in the lamp will be reduced and the lamp may rupture (often making a loud noise when this happens). If the lamp ruptures, the TV will not operate until the lamp unit is replaced.

Note: The lamp unit is designed so broken lamp glass remains securely inside the lamp unit.



CAUTION: Always handle the lamp unit with care.

The lamp unit in this TV was designed for safe replacement by consumers; however, if the lamp unit is subjected to intentional abuse (such as excessive mechanical abuse or handling by children or pets), the unit may break, exposing edges or pinch points.

When to replace the lamp unit

You should replace the lamp unit:

- if the picture darkens and/or colors fade;
- if the lamp does not light; or
- If you hear a loud noise and the picture goes black, which may indicate a lamp rupture (LED indication #8). See LED indications on page 6.

Note: Be sure wear the gloves before replacing the lamp unit.

1. Turn off the TV and unplug the power cord.



2. STOP! Allow the lamp to cool for at least one (1) hour before replacing it.



3. On the back of the TV, loosen the thumb screw (by hand) on the lamp unit door, and then remove the lamp unit door.

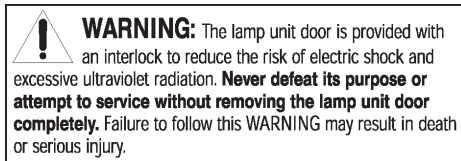
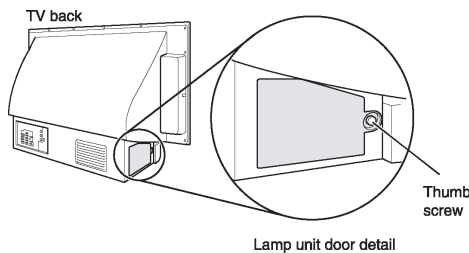

4. Using a manual screwdriver, loosen two screws on the lamp unit.

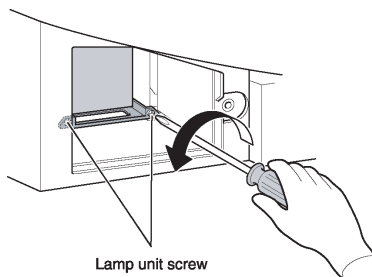

5. Grasp the lamp unit handle and gently pull the lamp unit straight out of the TV. Set the old lamp unit aside.

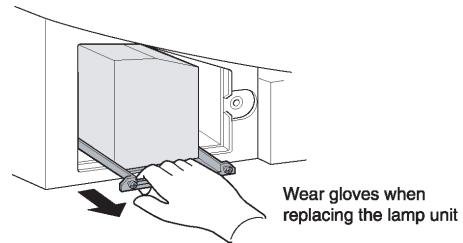

6. Carefully insert the new lamp unit straight into the TV until it is fully seated.

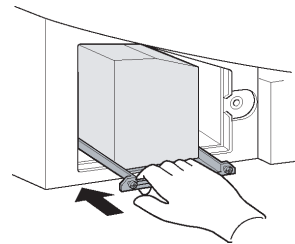

Note :

- Never subject the lamp unit to excessive shock.
- Never touch the lamp unit glass or otherwise get it dirty.
- Doing so may affect the image quality and reduce the service life of the lamp. See “Cleaning the lamp unit glass” below.

7. Using a manual screwdriver, tighten two lamp unit screws.

Note: Hand-tighten only. Do not use an electric screwdriver.

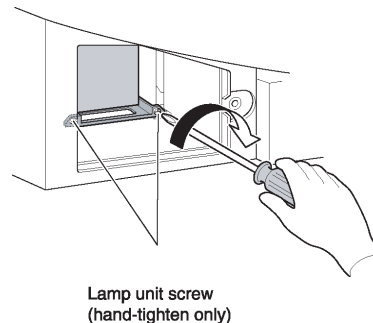

Cleaning the lamp unit glass

If you accidentally touch the lamp unit glass or otherwise get it dirty, wipe it with a lint-free lens cleaning cloth (such as a cloth for cleaning camera lenses or eyeglasses).

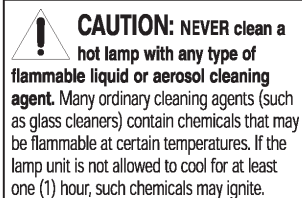

8. Reattach the lamp unit door, making sure to insert the hook on the left side of the lamp unit door inside the opening in the TV cabinet.

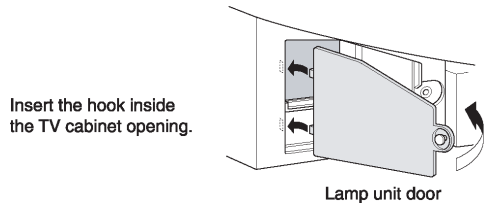

9. Replace the thumb screw and hand-tighten.

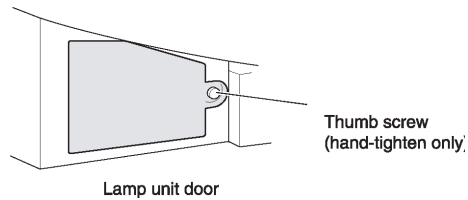

 **NOTE:** Make sure the lamp unit and screw are installed securely; otherwise, the TV may not turn on and the lamp life may be shortened.

10. Plug in the power cord and turn on the TV. After the initial warmup period (which may take up to 45 seconds for full picture brightness), the TV should operate normally. If any of the following conditions exist, turn off the TV, unplug the power cord, and repeat steps 1-9 to ensure that the lamp unit and lamp unit door are installed correctly:
- No picture
 - Dark picture
 - TV will not turn on

LIGHT ENGINE REPLACEMENT

Cautions when replacing LIGHT ENGINE

LIGHT ENGINE UNIT:

A271 : LV-672 TB 0B ; 52HM85, LV-672 TB 0D ; 62HM85
(Including with E998Z, SK01 to SK04, SK06, SK08
and SK09.)

- LIGHT ENGINE is a heart of the TV and emits high heat. Make sure to replace it after turning off the TV and wait for sufficient cool down. (More than one hour is recommended.)
- Do not impact during replacement; otherwise, some parts may be damaged.
- Do not touch optical lens. Adhesion of dirt may deteriorate its performance.
- Do not loosen any screw other than those to be removed for adjustment or replacement.
- LIGHT ENGINE emits ultraviolet rays when the TV is ON. Make sure to be careful.

1. Replacement of Light Engine Unit

1-1. When Light Engine Unit is replaced with a new one, adjustment is required. Adjusted values are described in bar code, and the values of bar code must be converted to the adjusted values for the setup. There are 2 types of bar code.

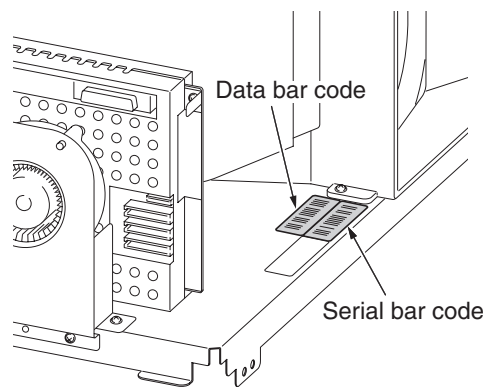

Serial bar code

Ex. 52A000A111111

Inch size Serial numbers

Data bar code (CW: color wheel)

Ex. A000000B1111

CWdelay number: 4digits

DMD bias value

Substrate serial numbers

1-2. Adjustment is made from service mode. The adjusting items consist of CWDL, CWDH and DMDB.

CWDL **CWDH**

When CW delay number of the data bar code is 0450:

0450 indicates \Rightarrow 450 \Rightarrow 45.0

Double 45.0 to form hexadecimal number (HEX).

$45.0 \times 2 = 90 \Rightarrow$ 5A (hexadecimal)

The adjusted value becomes "5A" for CWDL and "00" for CWDH.

If hexadecimal number forms 3 or 4 digits, the latter 2 digits indicate CWDL while the first 2 digits indicate CWDH.

(For 3 digits, CWDH=0*)

Note:

For converting decimal number to hexadecimal number, see the conversion table on the next page.

DMDB

Read DMD bias value described in alphabet from the data bar code. In service mode, DMDB value is converted and fixed by the following table.

DMD value in bar code	Adjusted value (Hex)
B	00
C	01
D	02
E	03
F	04

Refer to Service Mode for adjusting the service mode.

Conversion Table for Decimal and Hexadecimal Numbers

CW delay number	CWDH	CWDL	CW delay number	CWDH	CWDL	CW delay number	CWDH	CWDL	CW delay number	CWDH	CWDL	CW delay number	CWDH	CWDL
0000	00	00	0370	00	4A	0740	00	94	1110	00	DE	1480	01	28
0005	00	01	0375	00	4B	0745	00	95	1115	00	DF	1485	01	29
0010	00	02	0380	00	4C	0750	00	96	1120	00	E0	1490	01	2A
0015	00	03	0385	00	4D	0755	00	97	1125	00	E1	1495	01	2B
0020	00	04	0390	00	4E	0760	00	98	1130	00	E2	1500	01	2C
0025	00	05	0395	00	4F	0765	00	99	1135	00	E3	1505	01	2D
0030	00	06	0400	00	50	0770	00	9A	1140	00	E4	1510	01	2E
0035	00	07	0405	00	51	0775	00	9B	1145	00	E5	1515	01	2F
0040	00	08	0410	00	52	0780	00	9C	1150	00	E6	1520	01	30
0045	00	09	0415	00	53	0785	00	9D	1155	00	E7	1525	01	31
0050	00	0A	0420	00	54	0790	00	9E	1160	00	E8	1530	01	32
0055	00	0B	0425	00	55	0795	00	9F	1165	00	E9	1535	01	33
0060	00	0C	0430	00	56	0800	00	A0	1170	00	EA	1540	01	34
0065	00	0D	0435	00	57	0805	00	A1	1175	00	EB	1545	01	35
0070	00	0E	0440	00	58	0810	00	A2	1180	00	EC	1550	01	36
0075	00	0F	0445	00	59	0815	00	A3	1185	00	ED	1555	01	37
0080	00	10	0450	00	5A	0820	00	A4	1190	00	EE	1560	01	38
0085	00	11	0455	00	5B	0825	00	A5	1195	00	EF	1565	01	39
0090	00	12	0460	00	5C	0830	00	A6	1200	00	F0	1570	01	3A
0095	00	13	0465	00	5D	0835	00	A7	1205	00	F1	1575	01	3B
0100	00	14	0470	00	5E	0840	00	A8	1210	00	F2	1580	01	3C
0105	00	15	0475	00	5F	0845	00	A9	1215	00	F3	1585	01	3D
0110	00	16	0480	00	60	0850	00	AA	1220	00	F4	1590	01	3E
0115	00	17	0485	00	61	0855	00	AB	1225	00	F5	1595	01	3F
0120	00	18	0490	00	62	0860	00	AC	1230	00	F6	1600	01	40
0125	00	19	0495	00	63	0865	00	AD	1235	00	F7	1605	01	41
0130	00	1A	0500	00	64	0870	00	AE	1240	00	F8	1610	01	42
0135	00	1B	0505	00	65	0875	00	AF	1245	00	F9	1615	01	43
0140	00	1C	0510	00	66	0880	00	B0	1250	00	FA	1620	01	44
0145	00	1D	0515	00	67	0885	00	B1	1255	00	FB	1625	01	45
0150	00	1E	0520	00	68	0890	00	B2	1260	00	FC	1630	01	46
0155	00	1F	0525	00	69	0895	00	B3	1265	00	FD	1635	01	47
0160	00	20	0530	00	6A	0900	00	B4	1270	00	FE	1640	01	48
0165	00	21	0535	00	6B	0905	00	B5	1275	00	FF	1645	01	49
0170	00	22	0540	00	6C	0910	00	B6	1280	01	00	1650	01	4A
0175	00	23	0545	00	6D	0915	00	B7	1285	01	01	1655	01	4B
0180	00	24	0550	00	6E	0920	00	B8	1290	01	02	1660	01	4C
0185	00	25	0555	00	6F	0925	00	B9	1295	01	03	1665	01	4D
0190	00	26	0560	00	70	0930	00	BA	1300	01	04	1670	01	4E
0195	00	27	0565	00	71	0935	00	BB	1305	01	05	1675	01	4F
0200	00	28	0570	00	72	0940	00	BC	1310	01	06	1680	01	50
0205	00	29	0575	00	73	0945	00	BD	1315	01	07	1685	01	51
0210	00	2A	0580	00	74	0950	00	BE	1320	01	08	1690	01	52
0215	00	2B	0585	00	75	0955	00	BF	1325	01	09	1695	01	53
0220	00	2C	0590	00	76	0960	00	C0	1330	01	0A	1700	01	54
0225	00	2D	0595	00	77	0965	00	C1	1335	01	0B	1705	01	55
0230	00	2E	0600	00	78	0970	00	C2	1340	01	0C	1710	01	56
0235	00	2F	0605	00	79	0975	00	C3	1345	01	0D	1715	01	57
0240	00	30	0610	00	7A	0980	00	C4	1350	01	0E	1720	01	58
0245	00	31	0615	00	7B	0985	00	C5	1355	01	0F	1725	01	59
0250	00	32	0620	00	7C	0990	00	C6	1360	01	10	1730	01	5A
0255	00	33	0625	00	7D	0995	00	C7	1365	01	11	1735	01	5B
0260	00	34	0630	00	7E	1000	00	C8	1370	01	12	1740	01	5C
0265	00	35	0635	00	7F	1005	00	C9	1375	01	13	1745	01	5D
0270	00	36	0640	00	80	1010	00	CA	1380	01	14	1750	01	5E
0275	00	37	0645	00	81	1015	00	CB	1385	01	15	1755	01	5F
0280	00	38	0650	00	82	1020	00	CC	1390	01	16	1760	01	60
0285	00	39	0655	00	83	1025	00	CD	1395	01	17	1765	01	61
0290	00	3A	0660	00	84	1030	00	CE	1400	01	18	1770	01	62
0295	00	3B	0665	00	85	1035	00	CF	1405	01	19	1775	01	63
0300	00	3C	0670	00	86	1040	00	D0	1410	01	1A	1780	01	64
0305	00	3D	0675	00	87	1045	00	D1	1415	01	1B	1785	01	65
0310	00	3E	0680	00	88	1050	00	D2	1420	01	1C	1790	01	66
0315	00	3F	0685	00	89	1055	00	D3	1425	01	1D	1795	01	67
0320	00	40	0690	00	8A	1060	00	D4	1430	01	1E			
0325	00	41	0695	00	8B	1065	00	D5	1435	01	1F			
0330	00	42	0700	00	8C	1070	00	D6	1440	01	20			
0335	00	43	0705	00	8D	1075	00	D7	1445	01	21			
0340	00	44	0710	00	8E	1080	00	D8	1450	01	22			
0345	00	45	0715	00	8F	1085	00	D9	1455	01	23			
0350	00	46	0720	00	90	1090	00	DA	1460	01	24			
0355	00	47	0725	00	91	1095	00	DB	1465	01	25			
0360	00	48	0730	00	92	1100	00	DC	1470	01	26			
0365	00	49	0735	00	93	1105	00	DD	1475	01	27			

PARTS REPLACEMENT IN LIGHT ENGINE

1. Replacement of Lamp FAN (SK01)

- 1-1. Replace the FAN for cooling Lamp (SK01), remove 2 screws on the FAN hood, and then remove 4 screws on the FAN for cooling Lamp.

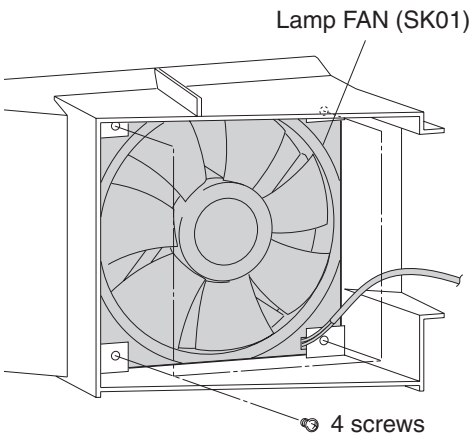
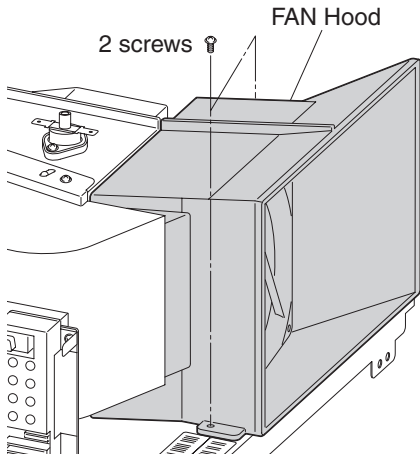

2. Replacement of Ballast FAN (SK03)

- 2-1. Replace the FAN for cooling Ballast Power Unit (SK03), remove the 4 pins by pressing into the unit, and then remove the FAN for cooling Ballast Power Unit.

NOTE:

Reinstalling the FAN for cooling Ballast Power Unit, attach the 4 pins by using removed them after replacing the FAN.

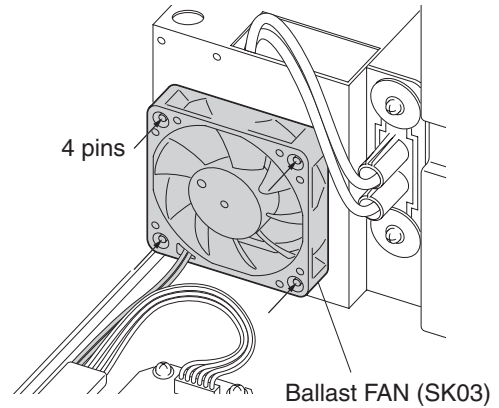

3. Replacement of DMD FAN (SK02) and FAN Transfer Cable (SK09)

- 3-1. Replace the FAN for cooling Formatter Board, detach the bracket with FAN by removing the 4 screws on the bracket.

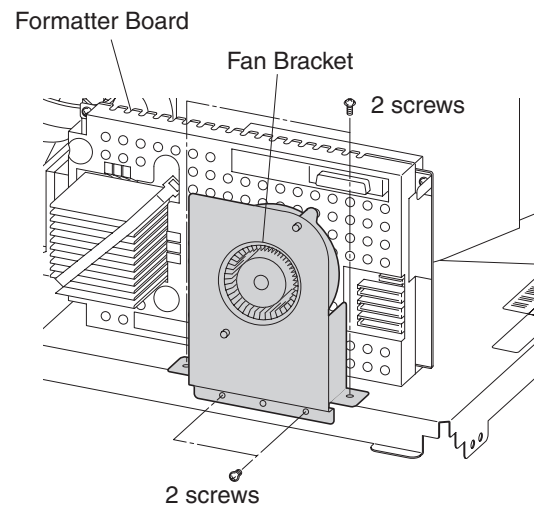

- 3-2. Remove the 2 screws from the bracket, and then remove the FAN for cooling Formatter Board (SK02).
- 3-3. Disconnect and replace the FAN transfer cable between Ballast and Formatter Boards (SK09).

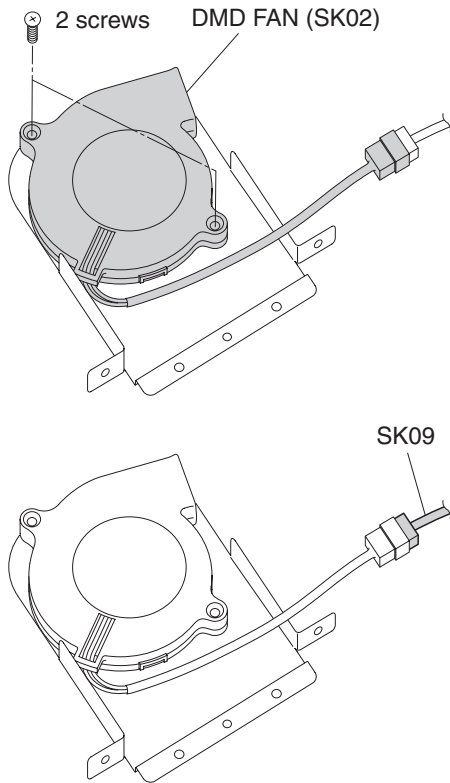

5. Replacement of Ballast to Formatter Board Cables (SK06 and SK08)

- 5-1. Disconnect and replace the cable between Ballast and Formatter Boards (SK06).
- 5-2. Disconnect and replace the cable between Smooth Picture and Formatter Boards (SK08).

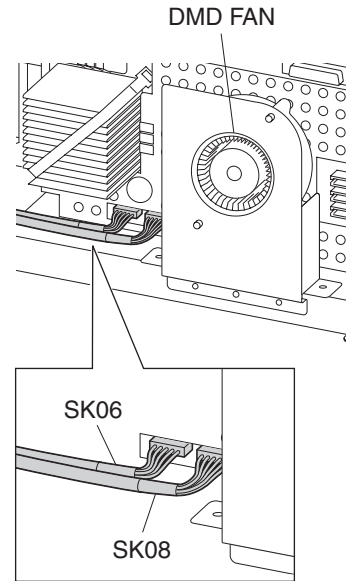

4. Replacement of Thermostat (Lamp Sensor) (SK04)

- 4-1. Replace the Thermostat (Lamp Sensor) (SK04), remove 2 screws on the Thermostat.

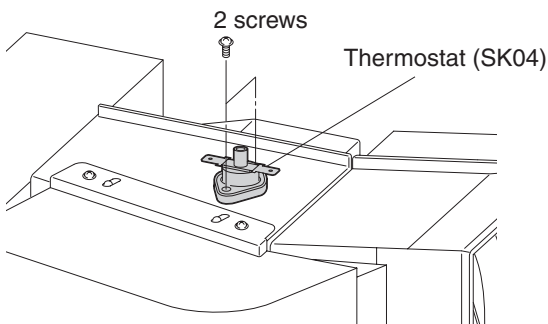

8. LIGHT ENGINE UNIT

Location No.	Parts No.	Description
△ A271 #1	23405474	OPTICAL ENGINE, LV-672 TB 0B (Incl. E998Z, SK01-SK04, SK06,SK08,SK09)
△ #2	23405474	OPTICAL ENGINE, LV-672 TB 0D (Incl. E998Z, SK01-SK04, SK06,SK08,SK09)
E998Z	23311153	EXCHANGE LAMP, PJ-D95-LMP
SK01	23587525	SERVICE KIT, LAMP FAN
SK02	23587526	SERVICE KIT, DMD FAN
SK03	23587527	SERVICE KIT, BALLAST FAN
SK04	23587528	SERVICE KIT, THERMOSTAT
SK06	23587536	SERVICE KIT, B TO F CABLE
SK08	23587538	SERVICE KIT, S TO F CABLE
SK09	23587539	SERVICE KIT, FAN TRANSFER CABLE

Note; #1: 52HM85 #2: 62HM85

EXPLODED VIEW

* Note ; A205 (Back Cover Assy) includes A204, W661 and W662 except A101.

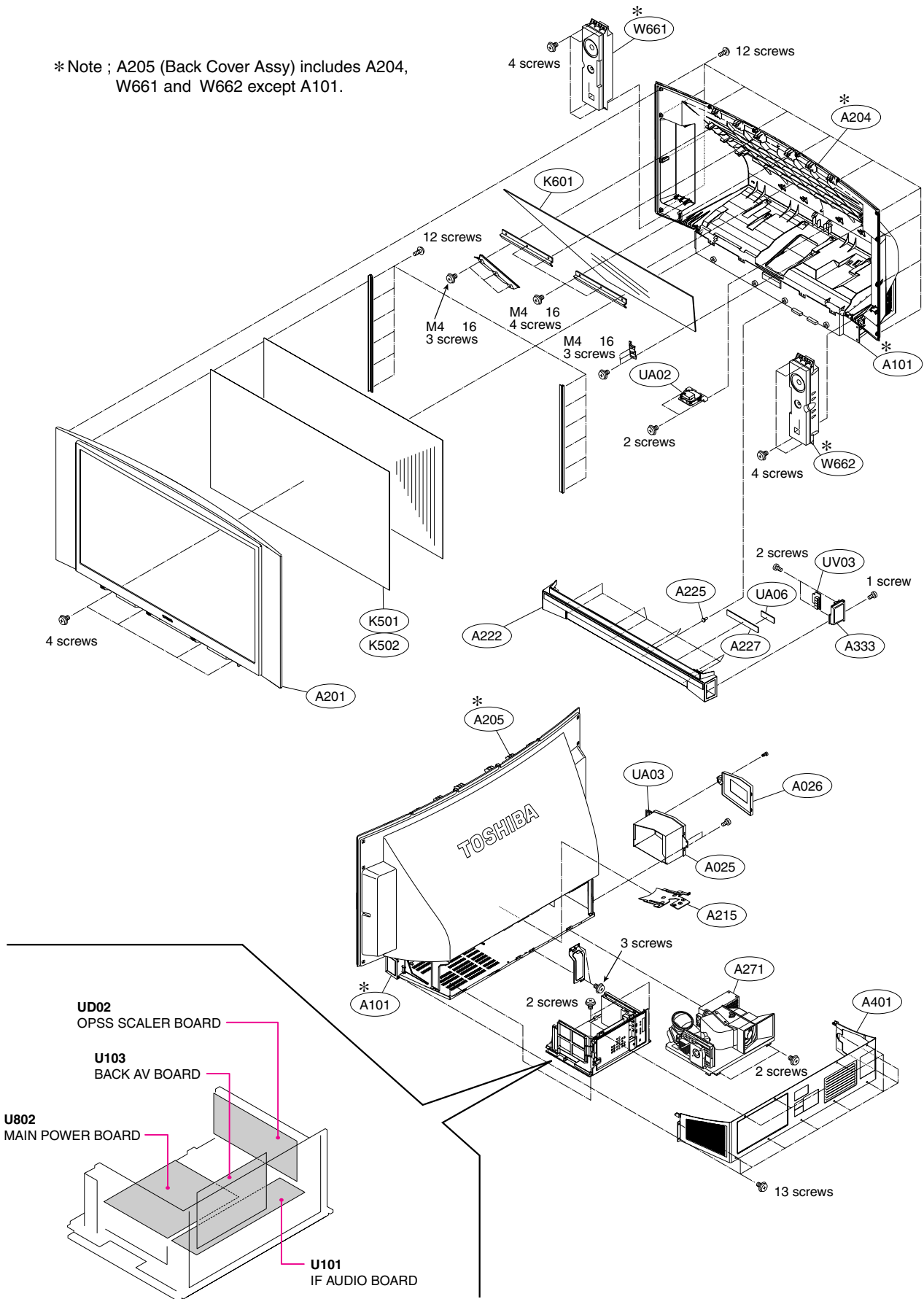

MECHANICAL DISASSEMBLY

1 Rear Cover Removal

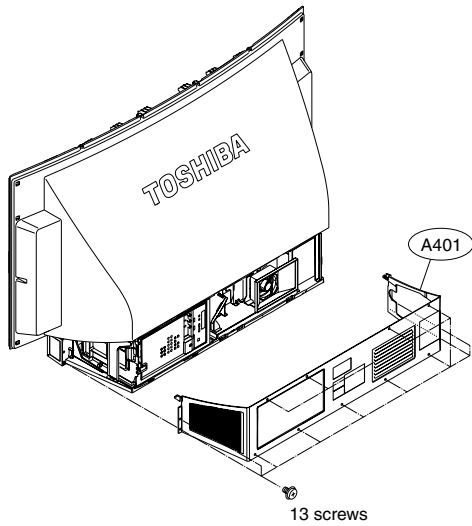

2 Touchpad & Bezel Ass'y Removal

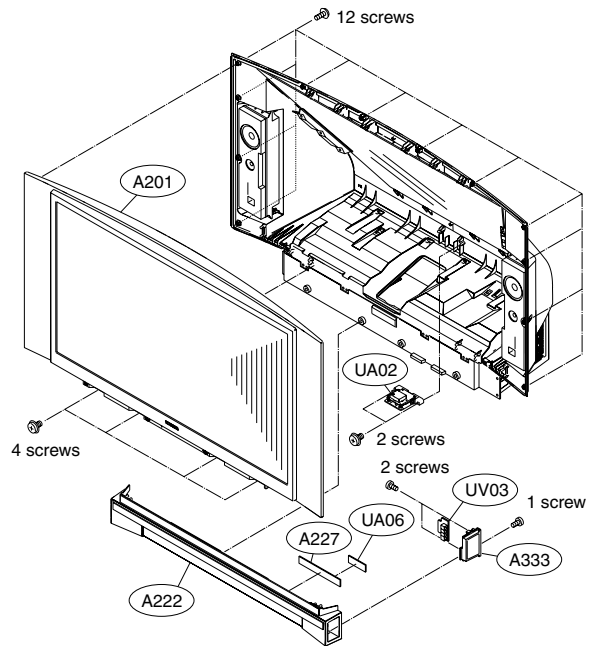

3 Mirror Removal

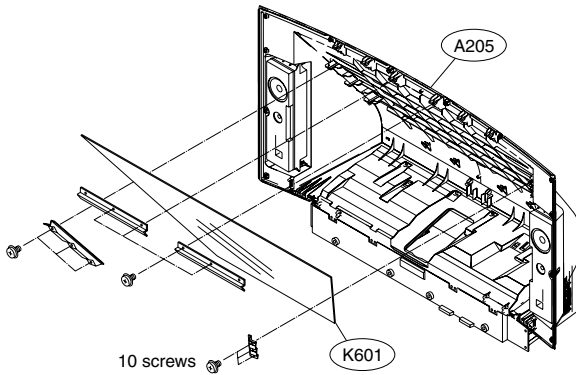

Note ; A205 includes A204, W661 and W662.

4 Speaker Removal

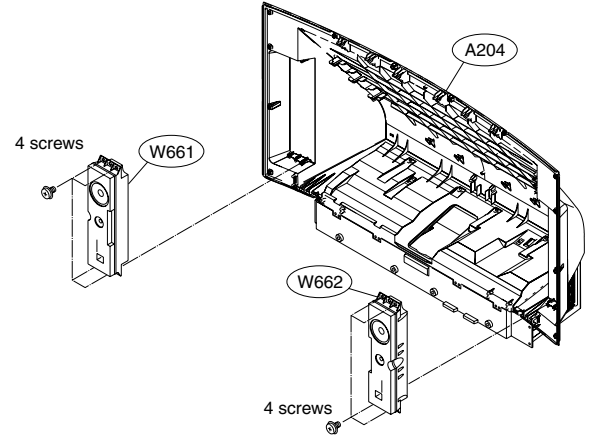

5 Bracket Removal

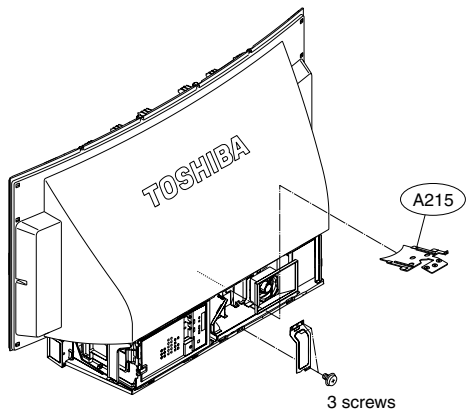

6 Optical Engine Removal

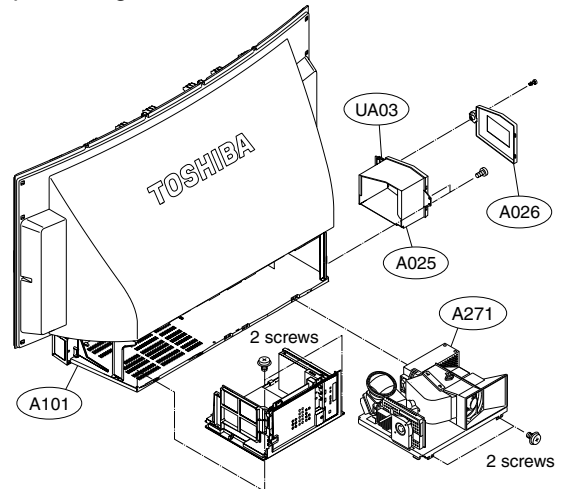

Location No.	Parts No.	Description
C8905	76073002	ELECTROLYTIC, 6.3V 220UF M 3A
C8911	76503047	PLASTIC FILM, 63V 0.33UF J
C8912	76503047	PLASTIC FILM, 63V 0.33UF J
C8921	76073141	ELECTROLYTIC, 10V 1000UF M 3A
C8930	76073067	ELECTROLYTIC, 35V 47UF M 3A
C8931	76503047	PLASTIC FILM, 63V 0.33UF J
C8932	76073152	ELECTROLYTIC, 16V 330UF M 3A
C8933	76073069	ELECTROLYTIC, 35V 220UF M 3A
C8940	76073067	ELECTROLYTIC, 35V 47UF M 3A
C8941	76503047	PLASTIC FILM, 63V 0.33UF J
C8942	76073152	ELECTROLYTIC, 16V 330UF M 3A
C8943	76073069	ELECTROLYTIC, 35V 220UF M 3A
CA81	76109333	CERAMIC CHIP, 25V B 0.033UF K
CA82	76109123	CERAMIC CHIP, 50V B 0.012UF K
CA83	76109103	CERAMIC CHIP, 50V B 0.01UF K
CA84	76109333	CERAMIC CHIP, 25V B 0.033UF K
CA85	76109273	CERAMIC CHIP, 25V B 0.027UF K
CA86	76109123	CERAMIC CHIP, 50V B 0.012UF K
CA87	76109123	CERAMIC CHIP, 50V B 0.012UF K
CA88	76109333	CERAMIC CHIP, 25V B 0.033UF K
CA91	76092730	CERAMIC CHIP, 16V B 0.1UF K
CA92	76092730	CERAMIC CHIP, 16V B 0.1UF K
CA93	76619040	ELECTROLYTIC CHIP, 16V 10UF M 3A
CA94	76619040	ELECTROLYTIC CHIP, 16V 10UF M 3A
CA95	76092730	CERAMIC CHIP, 16V B 0.1UF K
CA96	76092730	CERAMIC CHIP, 16V B 0.1UF K
CA914	76619040	ELECTROLYTIC CHIP, 16V 10UF M 3A
CA915	76092730	CERAMIC CHIP, 16V B 0.1UF K
CA916	76092730	CERAMIC CHIP, 16V B 0.1UF K
CB01	76794470	ELECTROLYTIC, 16V 47UF M
CB81	76092730	CERAMIC CHIP, 16V B 0.1UF K
CB82	76092730	CERAMIC CHIP, 16V B 0.1UF K
CB83	76092730	CERAMIC CHIP, 16V B 0.1UF K
CB99	76092730	CERAMIC CHIP, 16V B 0.1UF K
CS01	76092795	CERAMIC CHIP, 6.3V B 2.2UF K
CS02	76092795	CERAMIC CHIP, 6.3V B 2.2UF K
CS03	76092795	CERAMIC CHIP, 6.3V B 2.2UF K
CS04	76092795	CERAMIC CHIP, 6.3V B 2.2UF K
CS05	76092795	CERAMIC CHIP, 6.3V B 2.2UF K
CS06	76092795	CERAMIC CHIP, 6.3V B 2.2UF K
CS07	76092795	CERAMIC CHIP, 6.3V B 2.2UF K
CS08	76092795	CERAMIC CHIP, 6.3V B 2.2UF K
CS09	76092795	CERAMIC CHIP, 6.3V B 2.2UF K
CS10	76092795	CERAMIC CHIP, 6.3V B 2.2UF K
CS11	76092795	CERAMIC CHIP, 6.3V B 2.2UF K
CS12	76092795	CERAMIC CHIP, 6.3V B 2.2UF K
CS13	76092795	CERAMIC CHIP, 6.3V B 2.2UF K
CS14	76092795	CERAMIC CHIP, 6.3V B 2.2UF K
CS15	76092795	CERAMIC CHIP, 6.3V B 2.2UF K
CS16	76092795	CERAMIC CHIP, 6.3V B 2.2UF K
CS25	76109103	CERAMIC CHIP, 50V B 0.01UF K
CS26	76794470	ELECTROLYTIC, 16V 47UF M
CS27	76794220	ELECTROLYTIC, 16V 22UF M
CS28	76794100	ELECTROLYTIC, 16V 10UF M
CS29	76794100	ELECTROLYTIC, 16V 10UF M
CS30	76794100	ELECTROLYTIC, 16V 10UF M
CV01	76092621	CERAMIC CHIP, 10V B 1UF K
CV02	76092621	CERAMIC CHIP, 10V B 1UF K
CV03	76092621	CERAMIC CHIP, 10V B 1UF K
CV04	76100104	CERAMIC CHIP, 25V F 0.1UF Z
CV05	76092621	CERAMIC CHIP, 10V B 1UF K
CV06	76092621	CERAMIC CHIP, 10V B 1UF K
CV10	76100104	CERAMIC CHIP, 25V F 0.1UF Z
CV11	76092621	CERAMIC CHIP, 10V B 1UF K
CV13	76100104	CERAMIC CHIP, 25V F 0.1UF Z @U103
	76794100	ELECTROLYTIC, 16V 10UF M @UV03
CV14	76092621	CERAMIC CHIP, 10V B 1UF K @U103
	76232103	CERAMIC DISC, 50V F 0.01UF Z @UV03
CV15	76100104	CERAMIC CHIP, 25V F 0.1UF Z @U103
	76232103	CERAMIC DISC, 50V F 0.01UF Z @UV03
CV27	76762471	ELECTROLYTIC, 10V 470UF M
CV29	76763101	ELECTROLYTIC, 16V 100UF M
CV30	76092730	CERAMIC CHIP, 16V B 0.1UF K
CV38	76109102	CERAMIC CHIP, 50V B 1000PF K
CV39	76109102	CERAMIC CHIP, 50V B 1000PF K
CV47	76092621	CERAMIC CHIP, 10V B 1UF K

Location No.	Parts No.	Description
CV70	76794101	ELECTROLYTIC, 16V 100UF M
CV71	76092621	CERAMIC CHIP, 10V B 1UF K
CV72	76794220	ELECTROLYTIC, 16V 22UF M
CV245	76092621	CERAMIC CHIP, 10V B 1UF K
CV246	76092621	CERAMIC CHIP, 10V B 1UF K
CV247	76092621	CERAMIC CHIP, 10V B 1UF K
CV249	76092621	CERAMIC CHIP, 10V B 1UF K
CV250	76092621	CERAMIC CHIP, 10V B 1UF K
CV251	76092621	CERAMIC CHIP, 10V B 1UF K
CV253	76092621	CERAMIC CHIP, 10V B 1UF K
CV254	76092621	CERAMIC CHIP, 10V B 1UF K
CV255	76092621	CERAMIC CHIP, 10V B 1UF K
CY101	76092441	CERAMIC CHIP, 16V F 1UF Z
CY102	76665221	ELECTROLYTIC, 10V 220UF M 3A @U101
	76794101	ELECTROLYTIC, 16V 100UF M @U103
CY103	76100104	CERAMIC CHIP, 25V F 0.1UF Z
CY104	76109103	CERAMIC CHIP, 50V B 0.01UF K
CY105	76100102	CERAMIC CHIP, 50V F 1000PF Z @U101
	76109103	CERAMIC CHIP, 50V B 0.01UF K @U103
CY106	76109103	CERAMIC CHIP, 50V B 0.01UF K
CY107	76794100	ELECTROLYTIC, 16V 10UF M
CY108	76100104	CERAMIC CHIP, 25V F 0.1UF Z
CY109	76105101	CERAMIC CHIP, 50V CH 100PF J
CY111	76109103	CERAMIC CHIP, 50V B 0.01UF K
CY112	76105181	CERAMIC CHIP, 50V CH 180PF J
CY113	76109103	CERAMIC CHIP, 50V B 0.01UF K
CY114	76109103	CERAMIC CHIP, 50V B 0.01UF K
CY115	76105390	CERAMIC CHIP, 50V CH 39PF J
CY116	76105470	CERAMIC CHIP, 50V CH 47PF J
CY117	76105180	CERAMIC CHIP, 50V CH 18PF J
CY160	76815393	CERAMIC CHIP, 50V B 0.039UF K
CY501	76109103	CERAMIC CHIP, 50V B 0.01UF K
CY502	76092730	CERAMIC CHIP, 16V B 0.1UF K
CY504	76109222	CERAMIC CHIP, 50V B 2200PF K
CY505	76105120	CERAMIC CHIP, 50V CH 12PF J
CY506	76109103	CERAMIC CHIP, 50V B 0.01UF K
CY508	76092730	CERAMIC CHIP, 16V B 0.1UF K
CY512	76092463	CERAMIC CHIP, 16V B 0.22UF K
CY513	76092730	CERAMIC CHIP, 16V B 0.1UF K
CY514	76092730	CERAMIC CHIP, 16V B 0.1UF K
CY515	76092730	CERAMIC CHIP, 16V B 0.1UF K
CY516	76109103	CERAMIC CHIP, 50V B 0.01UF K
CY517	76092731	CERAMIC CHIP, 16V B 1UF K
CY524	76092730	CERAMIC CHIP, 16V B 0.1UF K
CY525	76092730	CERAMIC CHIP, 16V B 0.1UF K
CY526	76092730	CERAMIC CHIP, 16V B 0.1UF K
CY538	76761102	ELECTROLYTIC, 6.3V 1000UF M
CY539	76794471	ELECTROLYTIC, 16V 470UF M
CY540	76794471	ELECTROLYTIC, 16V 470UF M
CY541	76761102	ELECTROLYTIC, 6.3V 1000UF M
CY582	76105101	CERAMIC CHIP, 50V CH 100PF J

RESISTORS		
R010	76011102	CHIP, 1/20W 1K OHM J
R150	76011332	CHIP, 1/20W 3.3K OHM J
R151	76011562	CHIP, 1/20W 5.6K OHM J
R152	76011103	CHIP, 1/20W 10K OHM J
R173	76011103	CHIP, 1/20W 10K OHM J
R174	76011273	CHIP, 1/20W 27K OHM J
R264	76011750	CHIP, 1/20W 75 OHM J
R265	76011750	CHIP, 1/20W 75 OHM J
R266	76011750	CHIP, 1/20W 75 OHM J
R286	76011750	CHIP, 1/20W 75 OHM J
R287	76011750	CHIP, 1/20W 75 OHM J
R288	76011750	CHIP, 1/20W 75 OHM J
R347	76011101	CHIP, 1/20W 100 OHM J
R348	76011101	CHIP, 1/20W 100 OHM J
R601	76011822	CHIP, 1/20W 8.2K OHM J
R602	76011822	CHIP, 1/20W 8.2K OHM J
R603	76011122	CHIP, 1/20W 1.2K OHM J
R604	76011122	CHIP, 1/20W 1.2K OHM J
R609	76011563	CHIP, 1/20W 56K OHM J
R610	76011223	CHIP, 1/20W 22K OHM J
R611	76011103	CHIP, 1/20W 10K OHM J
R612	76011222	CHIP, 1/20W 2.2K OHM J
R613	76011223	CHIP, 1/20W 22K OHM J

Location No.	Parts No.	Description
R614	76011103	CHIP, 1/20W 10K OHM J
R615	76011104	CHIP, 1/20W 100K OHM J
R616	76011822	CHIP, 1/20W 8.2K OHM J
R621	76011391	CHIP, 1/20W 390 OHM J
R622	76011391	CHIP, 1/20W 390 OHM J
R626	76011223	CHIP, 1/20W 22K OHM J
R627	76011223	CHIP, 1/20W 22K OHM J
R661	76011102	CHIP, 1/20W 1K OHM J
R662	76011333	CHIP, 1/20W 33K OHM J
R663	76011822	CHIP, 1/20W 8.2K OHM J
R665	76011223	CHIP, 1/20W 22K OHM J
R666	76011473	CHIP, 1/20W 47K OHM J
R667	76011223	CHIP, 1/20W 22K OHM J
R668	76011473	CHIP, 1/20W 47K OHM J
R671	76011102	CHIP, 1/20W 1K OHM J
R672	76011333	CHIP, 1/20W 33K OHM J
R673	76011822	CHIP, 1/20W 8.2K OHM J
R674	76011472	CHIP, 1/20W 4.7K OHM J
R676	76011104	CHIP, 1/20W 100K OHM J
R677	76011104	CHIP, 1/20W 100K OHM J
R681	76011222	CHIP, 1/20W 2.2K OHM J
R682	76011473	CHIP, 1/20W 47K OHM J
R683	76011223	CHIP, 1/20W 22K OHM J
R684	76011223	CHIP, 1/20W 22K OHM J
R687	76011103	CHIP, 1/20W 10K OHM J
R688	76011224	CHIP, 1/20W 220K OHM J
R693	76000445	CHIP JUMPER, 1608TYPE
R697	76553561	OXIDE METAL FILM, 1W 560 OHM J
R698	76011103	CHIP, 1/20W 10K OHM J
R699	76011103	CHIP, 1/20W 10K OHM J
R810	76568479	CERAMIC COVERED, 7W 4.7 OHM J
R811	76120001	CEMENT RES 141C 2.1W 1R8 K
R840	76552562	OXIDE METAL FILM, 1/2W 5.6K OHM J
R841	76366102	CARBON FILM, 1/6W 1K OHM J
R842	76376563	CARBON FILM, 1/2W 56K OHM J
R843	76376563	CARBON FILM, 1/2W 56K OHM J
R844	76366103	CARBON FILM, 1/6W 10K OHM J
R845	76366102	CARBON FILM, 1/6W 1K OHM J
R846	76366471	CARBON FILM, 1/6W 470 OHM J
R847	76366473	CARBON FILM, 1/6W 47K OHM J
R848	76366102	CARBON FILM, 1/6W 1K OHM J
R849	76552470	OXIDE METAL FILM, 1/2W 47 OHM J
R850	76366103	CARBON FILM, 1/6W 10K OHM J
R860	76382101	OXIDE METAL FILM, 1W 100 OHM J
R861	76383333	OXIDE METAL FILM, 2W 33K OHM J
R862	76019463	METAL PLATE, 2W 0.22 OHM J
R863	76019461	METAL PLATE, 2W 0.15 OHM J
R864	76321828	METAL FILM, 1/2W 0.82 OHM J
R865	76381221	OXIDE METAL FILM, 1/2W 220 OHM J
R866	76366681	CARBON FILM, 1/6W 680 OHM J
R867	76366152	CARBON FILM, 1/6W 1.5K OHM J
R868	76555473	OXIDE METAL FILM, 3W 47K OHM J
R869	76366152	CARBON FILM, 1/6W 1.5K OHM J
R870	76366154	CARBON FILM, 1/6W 150K OHM J
R881	76366222	CARBON FILM, 1/6W 2.2K OHM J
R882	76366471	CARBON FILM, 1/6W 470 OHM J
R885	76366102	CARBON FILM, 1/6W 1K OHM J
R886	76000525	METAL FILM, 1/4W 4.7K OHM F
R887	76367683	CARBON FILM, 1/6W 68K OHM G
R888	76000525	METAL FILM, 1/4W 4.7K OHM F
R889	76383222	OXIDE METAL FILM, 2W 2.2K OHM J
R891	76555331	OXIDE METAL FILM, 3W 330 OHM J
R892	76555331	OXIDE METAL FILM, 3W 330 OHM J
△ R899	76005014	METAL FILM, 1W 8.2M OHM J
R8200	76367390	CARBON FILM, 1/6W 390 OHM G
R8210	76000147	METAL FILM, 1/4W 470 OHM F
R8211	76000219	METAL FILM, 1/4W 10 OHM F
R8220	76367390	CARBON FILM, 1/6W 390 OHM G
R8240	76000635	METAL FILM, 1/4W 12K OHM F
R8241	76000529	RESISTOR, METAL FILM, 1/4W 6.8K OHM F
R8242	76367471	CARBON FILM, 1/6W 470 OHM G
R8250	76000145	METAL FILM, 1/4W 330 OHM F
R8251	76000145	METAL FILM, 1/4W 330 OHM F
R8252	76367392	CARBON FILM, 1/6W 3.9K OHM G
R8902	76366333	CARBON FILM, 1/6W 33K OHM J
R8903	76366333	CARBON FILM, 1/6W 33K OHM J

Location No.	Parts No.	Description
R8904	76366472	CARBON FILM, 1/6W 4.7K OHM J
R8905	76366681	CARBON FILM, 1/6W 680 OHM J
R8908	76366104	CARBON FILM, 1/6W 100K OHM J
R8910	76366472	CARBON FILM, 1/6W 4.7K OHM J
R8911	76366103	CARBON FILM, 1/6W 10K OHM J
R8912	76366223	CARBON FILM, 1/6W 22K OHM J
R8913	76366334	CARBON FILM, 1/6W 330K OHM J
R8914	76366223	CARBON FILM, 1/6W 22K OHM J
R8915	76366102	CARBON FILM, 1/6W 1K OHM J
R8922	76366122	CARBON FILM, 1/6W 1.2K OHM J
R8931	76367123	CARBON FILM, 1/6W 12K OHM G
R8932	76367182	CARBON FILM, 1/6W 1.8K OHM G
R8934	76367472	CARBON FILM, 1/6W 4.7K OHM G
R8941	76367123	CARBON FILM, 1/6W 12K OHM G
R8942	76367182	CARBON FILM, 1/6W 1.8K OHM G
R8944	76367472	CARBON FILM, 1/6W 4.7K OHM G
R8950	76366103	CARBON FILM, 1/6W 10K OHM J
R8951	76366103	CARBON FILM, 1/6W 10K OHM J
RA44	76011105	CHIP, 1/20W 1M OHM J
RA48	76011105	CHIP, 1/20W 1M OHM J
RA51	76011105	CHIP, 1/20W 1M OHM J
RA53	76011105	CHIP, 1/20W 1M OHM J
RA55	76011105	CHIP, 1/20W 1M OHM J
RA57	76011105	CHIP, 1/20W 1M OHM J
RA61	76011222	CHIP, 1/20W 2.2K OHM J
RA62	76011222	CHIP, 1/20W 2.2K OHM J
RA63	76011222	CHIP, 1/20W 2.2K OHM J
RA64	76011222	CHIP, 1/20W 2.2K OHM J
RA65	76011222	CHIP, 1/20W 2.2K OHM J
RA66	76011222	CHIP, 1/20W 2.2K OHM J
RA67	76011222	CHIP, 1/20W 2.2K OHM J
RA68	76011222	CHIP, 1/20W 2.2K OHM J
RA71	76011822	CHIP, 1/20W 8.2K OHM J
RA72	76011153	CHIP, 1/20W 15K OHM J
RA73	76011273	CHIP, 1/20W 27K OHM J
RA75	76011822	CHIP, 1/20W 8.2K OHM J
RA76	76011153	CHIP, 1/20W 15K OHM J
RA77	76011114	CHIP, 1/20W 110K OHM J
RA81	76011104	CHIP, 1/20W 100K OHM J
RA82	76011104	CHIP, 1/20W 100K OHM J
RA83	76011104	CHIP, 1/20W 100K OHM J
RA84	76011104	CHIP, 1/20W 100K OHM J
RA85	76011104	CHIP, 1/20W 100K OHM J
RA86	76011104	CHIP, 1/20W 100K OHM J
RA87	76011104	CHIP, 1/20W 100K OHM J
RA88	76011104	CHIP, 1/20W 100K OHM J
RA91	76011623	CHIP, 1/20W 62K OHM J
RA94	76000445	CHIP JUMPER, 1608TYPE
RA95	76011623	CHIP, 1/20W 62K OHM J
RA98	76000445	CHIP JUMPER, 1608TYPE
RB15	76366471	CARBON FILM, 1/6W 470 OHM J
RB19	76366470	CARBON FILM, 1/6W 47 OHM J
RB81	76011222	CHIP, 1/20W 2.2K OHM J
RB82	76011471	CHIP, 1/20W 470 OHM J
RB83	76011102	CHIP, 1/20W 1K OHM J
RB84	76011473	CHIP, 1/20W 47K OHM J
RB87	76011394	CHIP, 1/20W 390K OHM J
RB88	76011394	CHIP, 1/20W 390K OHM J
RB89	76011103	CHIP, 1/20W 10K OHM J
RB90	76011302	CHIP, 1/20W 3K OHM J
RB92	76011473	CHIP, 1/20W 47K OHM J
RB93	76011102	CHIP, 1/20W 1K OHM J
RS01	76011562	CHIP, 1/20W 5.6K OHM J
RS02	76011562	CHIP, 1/20W 5.6K OHM J
RS03	76011101	CHIP, 1/20W 100 OHM J
RS04	76011101	CHIP, 1/20W 100 OHM J
RS05	76011562	CHIP, 1/20W 5.6K OHM J
RS06	76011562	CHIP, 1/20W 5.6K OHM J
RS07	76011562	CHIP, 1/20W 5.6K OHM J
RS08	76011562	CHIP, 1/20W 5.6K OHM J
RS09	76011562	CHIP, 1/20W 5.6K OHM J
RS10	76011562	CHIP, 1/20W 5.6K OHM J
RS11	76011562	CHIP, 1/20W 5.6K OHM J
RS12	76011562	CHIP, 1/20W 5.6K OHM J
RS13	76011562	CHIP, 1/20W 5.6K OHM J
RS14	76011562	CHIP, 1/20W 5.6K OHM J

Location No.	Parts No.	Description
RS15	76011562	CHIP, 1/20W 5.6K OHM J
RS16	76011562	CHIP, 1/20W 5.6K OHM J
RS21	76011101	CHIP, 1/20W 100 OHM J
RS22	76011101	CHIP, 1/20W 100 OHM J
RS23	76011101	CHIP, 1/20W 100 OHM J
RS24	76011101	CHIP, 1/20W 100 OHM J
RS27	76011101	CHIP, 1/20W 100 OHM J
RS28	76011101	CHIP, 1/20W 100 OHM J
RS29	76011682	CHIP, 1/20W 6.8K OHM J
RS30	76011182	CHIP, 1/20W 1.8K OHM J
RS31	76011100	CHIP, 1/20W 10 OHM J
RS32	76011222	CHIP, 1/20W 2.2K OHM J
RS33	76011222	CHIP, 1/20W 2.2K OHM J
RS34	76011472	CHIP, 1/20W 4.7K OHM J
RS35	76011102	CHIP, 1/20W 1K OHM J
RS36	76011102	CHIP, 1/20W 1K OHM J
RS37	76011223	CHIP, 1/20W 22K OHM J
RS38	76011223	CHIP, 1/20W 22K OHM J
RV001	76011102	CHIP, 1/20W 1K OHM J
RV01	76011101	CHIP, 1/20W 100 OHM J
RV002	76011101	CHIP, 1/20W 100 OHM J
RV003	76011102	CHIP, 1/20W 1K OHM J
RV03	76011101	CHIP, 1/20W 100 OHM J
RV004	76011101	CHIP, 1/20W 100 OHM J
RV005	76011102	CHIP, 1/20W 1K OHM J
RV006	76011101	CHIP, 1/20W 100 OHM J
RV06	76011101	CHIP, 1/20W 100 OHM J
RV007	76011102	CHIP, 1/20W 1K OHM J
RV07	76011562	CHIP, 1/20W 5.6K OHM J
RV008	76011101	CHIP, 1/20W 100 OHM J
RV08	76011101	CHIP, 1/20W 100 OHM J
RV009	76011101	CHIP, 1/20W 100 OHM J
RV09	76011101	CHIP, 1/20W 100 OHM J
RV11	76011101	CHIP, 1/20W 100 OHM J
RV12	76011101	CHIP, 1/20W 100 OHM J
RV14	76011562	CHIP, 1/20W 5.6K OHM J
RV15	76011101	CHIP, 1/20W 100 OHM J
RV17	76011101	CHIP, 1/20W 100 OHM J
RV19	76011101	CHIP, 1/20W 100 OHM J
RV20	76366750	CARBON FILM, 1/6W 75 OHM J
RV21	76011562	CHIP, 1/20W 5.6K OHM J @U103
	76366750	CARBON FILM, 1/6W 75 OHM J @UV03
RV22	76011101	CHIP, 1/20W 100 OHM J @U103
	76366750	CARBON FILM, 1/6W 75 OHM J @UV03
RV23	76011222	CHIP, 1/20W 2.2K OHM J @U103
	76366101	CARBON FILM, 1/6W 100 OHM J @UV03
RV24	76011222	CHIP, 1/20W 2.2K OHM J
RV32	76011104	CHIP, 1/20W 100K OHM J
RV33	76011104	CHIP, 1/20W 100K OHM J
RV34	76011104	CHIP, 1/20W 100K OHM J
RV35	76011750	CHIP, 1/20W 75 OHM J
RV36	76011750	CHIP, 1/20W 75 OHM J
RV37	76011101	CHIP, 1/20W 100 OHM J
RV38	76011562	CHIP, 1/20W 5.6K OHM J
RV40	76011750	CHIP, 1/20W 75 OHM J
RV41	76011750	CHIP, 1/20W 75 OHM J
RV42	76011750	CHIP, 1/20W 75 OHM J
RV43	76011750	CHIP, 1/20W 75 OHM J
RV61	76011101	CHIP, 1/20W 100 OHM J
RV85	76366471	CARBON FILM, 1/6W 470 OHM J
RV86	76366471	CARBON FILM, 1/6W 470 OHM J
RV89	76011680	CHIP, 1/20W 68 OHM J
RV147	76011101	CHIP, 1/20W 100 OHM J
RV148	76011101	CHIP, 1/20W 100 OHM J
RV323	76011101	CHIP, 1/20W 100 OHM J
RV324	76011101	CHIP, 1/20W 100 OHM J
RV325	76011101	CHIP, 1/20W 100 OHM J
RV330	76011101	CHIP, 1/20W 100 OHM J
RV331	76011101	CHIP, 1/20W 100 OHM J
RV332	76011101	CHIP, 1/20W 100 OHM J
RV333	76011181	CHIP, 1/20W 180 OHM J
RV334	76011103	CHIP, 1/20W 10K OHM J
RV335	76011123	CHIP, 1/20W 12K OHM J
RV346	76011101	CHIP, 1/20W 100 OHM J
RY101	76011101	CHIP, 1/20W 100 OHM J

Location No.	Parts No.	Description
RY102	76011221	CHIP, 1/20W 220 OHM J
RY103	76011102	CHIP, 1/20W 1K OHM J
RY104	76011102	CHIP, 1/20W 1K OHM J
RY105	76011821	CHIP, 1/20W 820 OHM J
RY106	76000445	CHIP JUMPER, 1608TYPE
RY107	76011222	CHIP, 1/20W 2.2K OHM J
RY109	76011332	CHIP, 1/20W 3.3K OHM J
RY110	76011152	CHIP, 1/20W 1.5K OHM J
RY160	76011471	CHIP, 1/20W 470 OHM J
RY161	76011101	CHIP, 1/20W 100 OHM J
RY501	76011303	CHIP, 1/20W 30K OHM J
RY502	76011103	CHIP, 1/20W 10K OHM J
RY504	76011103	CHIP, 1/20W 10K OHM J
RY505	76011123	CHIP, 1/20W 12K OHM J
RY507	76011102	CHIP, 1/20W 1K OHM J
RY508	76011222	CHIP, 1/20W 2.2K OHM J
RY509	76011472	CHIP, 1/20W 4.7K OHM J
RY510	76011152	CHIP, 1/20W 1.5K OHM J
RY511	76011222	CHIP, 1/20W 2.2K OHM J
RY512	76011222	CHIP, 1/20W 2.2K OHM J
RY513	76011152	CHIP, 1/20W 1.5K OHM J
RY516	76011472	CHIP, 1/20W 4.7K OHM J
RY517	76011472	CHIP, 1/20W 4.7K OHM J
RY518	76011472	CHIP, 1/20W 4.7K OHM J
RY519	76000445	CHIP JUMPER, 1608TYPE
RY520	76011101	CHIP, 1/20W 100 OHM J
RY521	76011101	CHIP, 1/20W 100 OHM J
RY523	76011102	CHIP, 1/20W 1K OHM J
RY524	76011102	CHIP, 1/20W 1K OHM J
RY525	76011222	CHIP, 1/20W 2.2K OHM J
RY526	76011222	CHIP, 1/20W 2.2K OHM J
RY527	76011222	CHIP, 1/20W 2.2K OHM J
RY528	76011222	CHIP, 1/20W 2.2K OHM J
RY529	76011102	CHIP, 1/20W 1K OHM J
RY530	76011102	CHIP, 1/20W 1K OHM J
RY531	76011102	CHIP, 1/20W 1K OHM J
RY532	76011101	CHIP, 1/20W 100 OHM J
RY533	76011102	CHIP, 1/20W 1K OHM J
RY534	76011102	CHIP, 1/20W 1K OHM J
RY535	76011330	CHIP, 1/20W 33 OHM J
RY536	76011330	CHIP, 1/20W 33 OHM J
RY541	76011392	CHIP, 1/20W 3.9K OHM J
RY542	76011392	CHIP, 1/20W 3.9K OHM J
RY543	76011152	CHIP, 1/20W 1.5K OHM J
RY545	76011101	CHIP, 1/20W 100 OHM J
RY548	76011102	CHIP, 1/20W 1K OHM J
RY550	76011182	CHIP, 1/20W 1.8K OHM J
RY551	76011182	CHIP, 1/20W 1.8K OHM J
RY552	76011152	CHIP, 1/20W 1.5K OHM J
RY560	76011332	CHIP, 1/20W 3.3K OHM J
RY561	76011471	CHIP, 1/20W 470 OHM J
RY573	76011102	CHIP, 1/20W 1K OHM J
RY575	76011103	CHIP, 1/20W 10K OHM J
RY576	76011123	CHIP, 1/20W 12K OHM J
RY578	76011332	CHIP, 1/20W 3.3K OHM J
RY579	76011102	CHIP, 1/20W 1K OHM J
RY580	76011101	CHIP, 1/20W 100 OHM J
RY582	76011332	CHIP, 1/20W 3.3K OHM J
RY583	76011102	CHIP, 1/20W 1K OHM J
RY584	76011101	CHIP, 1/20W 100 OHM J
RY585	76011103	CHIP, 1/20W 10K OHM J
RY586	76011330	CHIP, 1/20W 33 OHM J
RY587	76011330	CHIP, 1/20W 33 OHM J
RY588	76011330	CHIP, 1/20W 33 OHM J
RY589	76000445	CHIP JUMPER, 1608TYPE
RY590	76011103	CHIP, 1/20W 10K OHM J
RY591	76011101	CHIP, 1/20W 100 OHM J
RY592	76011101	CHIP, 1/20W 100 OHM J
RY593	76011330	CHIP, 1/20W 33 OHM J
RY594	76011330	CHIP, 1/20W 33 OHM J
RY595	76011330	CHIP, 1/20W 33 OHM J
RY596	76000445	CHIP JUMPER, 1608TYPE
G101	76011151	CHIP, 1/20W 150 OHM J
G102	76011151	CHIP, 1/20W 150 OHM J
GA89	76000445	CHIP JUMPER, 1608TYPE
GA90	76000445	CHIP JUMPER, 1608TYPE

Location No.	Parts No.	Description
GJ105	76000445	CHIP JUMPER, 1608TYPE
GR103	76000445	CHIP JUMPER, 1608TYPE
JR003	76000445	CHIP JUMPER, 1608TYPE
JR004	76000445	CHIP JUMPER, 1608TYPE
JR005	76000445	CHIP JUMPER, 1608TYPE
JR006	76000445	CHIP JUMPER, 1608TYPE
JR007	76000445	CHIP JUMPER, 1608TYPE
JR008	76000445	CHIP JUMPER, 1608TYPE
JR009	76000445	CHIP JUMPER, 1608TYPE
JR010	76000445	CHIP JUMPER, 1608TYPE
JR011	76000445	CHIP JUMPER, 1608TYPE
JR012	76000445	CHIP JUMPER, 1608TYPE
JR013	76000445	CHIP JUMPER, 1608TYPE
JR014	76000445	CHIP JUMPER, 1608TYPE
JR015	76000445	CHIP JUMPER, 1608TYPE
JR016	76000445	CHIP JUMPER, 1608TYPE
JR017	76000445	CHIP JUMPER, 1608TYPE
JR018	76000445	CHIP JUMPER, 1608TYPE
JR019	76000445	CHIP JUMPER, 1608TYPE
COILS & TRANSFORMERS		
L101	23289027	COIL, PEAKING, TRF4680AT
L103	23289026	COIL, PEAKING, TRF4470AT
L840	23289981	COIL, PEAKING, TRF4330AZ
L841	23103304	FERRITE CHOKE, TEM2011AA
L861	23103304	FERRITE CHOKE, TEM2011AA
L862	23103307	FERRITE CHOKE, TEM2014AA
L881	23103304	FERRITE CHOKE, TEM2011AA
L882	23103304	FERRITE CHOKE, TEM2011AA
L883	23103304	FERRITE CHOKE, TEM2011AA
L884	23103304	FERRITE CHOKE, TEM2011AA
L885	23103304	FERRITE CHOKE, TEM2011AA
L886	23103304	FERRITE CHOKE, TEM2011AA
L888	23248446	COIL, CHOKE, TLN3462AH
L890	23248432	COIL, CHOKE, TLN3499AH
L891	23248432	COIL, CHOKE, TLN3499AH
L892	23248432	COIL, CHOKE, TLN3499AH
L893	23248417	COIL, CHOKE, TLN3481AH
L895	23248432	COIL, CHOKE, TLN3499AH
L896	23289981	COIL, PEAKING, TRF4330AZ
L8210	23289981	COIL, PEAKING, TRF4330AZ
L8211	23248456	COIL, CHOKE, TLN3540AH
L8213	23248417	COIL, CHOKE, TLN3481AH
L8930	23248432	COIL, CHOKE, TLN3499AH
L8931	23248432	COIL, CHOKE, TLN3499AH
L8940	23248432	COIL, CHOKE, TLN3499AH
L8941	23248432	COIL, CHOKE, TLN3499AH
LV13	23246662	COIL, CHIP, TRF4100CN
LV20	23221156	COIL, PEAKING, TRF4560AJ
LY012	23246662	COIL, CHIP, TRF4100CN
LY100	23246656	COIL, CHIP, TRF4330CG
LY101	23248398	COIL, CHOKE, TLN3278D @U101
	23103827	INDUCTOR, BEAD, TEM2120M @U103
LY102	23221144	COIL, PEAKING, TRF4229AJ @U101
	23103827	INDUCTOR, BEAD, TEM2120M @U103
LY103	23221144	COIL, PEAKING, TRF4229AJ @U101
	23103230	INDUCTOR, BEAD, TEM2134AD @U103
LY104	23246653	COIL, CHIP, TRF4150CG
LY105	23246655	COIL, CHIP, TRF4270CG
LY112	23103230	INDUCTOR, BEAD, TEM2134AD
LY501	23246662	COIL, CHIP, TRF4100CN
LY503	23246662	COIL, CHIP, TRF4100CN
△ T801	23211827	COIL, LINE FILTER, TRF3239AH
△ T802	23211836	COIL, LINE FILTER, TRF3197AH
△ T840	23217790	TRANSFORMER, CONVERTER TPW3425BH
△ T862	23217682	TRANSFORMER, CONVERTER, TPW3553AS
M802A	23103839	FERRITE CORE, TFE1012
M811A	23103778	FERRITE CORE, TFE1008
M905A	23103778	FERRITE CORE, TFE1008
MB91A	23103840	FERRITE CORE, TFE1013
P800A	23103840	FERRITE CORE, TFE1013
ZB22B	23103840	FERRITE CORE, TFE1013
SEMICONDUCTORS		
Q151	23205346	TRANSISTOR, KTA2014Y/P
Q152	23205347	TRANSISTOR, KTC4075Y/P

Location No.	Parts No.	Description
Q172	23205347	TRANSISTOR, KTC4075Y/P
Q601	23009603	IC, AN7580
Q612	23205346	TRANSISTOR, KTA2014Y/P
Q613	23205347	TRANSISTOR, KTC4075Y/P
Q614	23205426	TRANSISTOR, KRC106S/P
Q661	23205424	TRANSISTOR, KTC2875B/P
Q662	23205424	TRANSISTOR, KTC2875B/P
Q663	23085575	IC, OP AMP, BA4558
Q664	23205428	TRANSISTOR, KRA104S/P
Q681	23205424	TRANSISTOR, KTC2875B/P
Q682	23205424	TRANSISTOR, KTC2875B/P
Q801	23135069	IC, STRF6268S
Q840	23085559	IC, MIP280
△ Q841	23000823	IC, PHOTO COUPLER, TLP421F(GR)
△ Q842	23000823	IC, PHOTO COUPLER, TLP421F(GR)
Q845	23205499	TRANSISTOR, KTC3198 Y/P
Q846	23205499	TRANSISTOR, KTC3198 Y/P
Q847	23205499	TRANSISTOR, KTC3198 Y/P
△ Q862	23000823	IC, PHOTO COUPLER, TLP421F(GR)
Q881	23085389	IC, NJM431L
Q8200	230855050	IC, SI-3120J(LF1101)
Q8210	23085397	IC, SI-8033SS
Q8220	23135077	IC, SI-3090CA
Q8240	23085821	IC, ADJ REG. VO=1.5V-16.0V BA7810T-V5
Q8250	23085377	IC, PQ5EV3J0000H
Q8251	23085600	IC, PST9129
Q8901	23205499	TRANSISTOR, KTC3198 Y/P
Q8902	23205499	TRANSISTOR, KTC3198 Y/P
Q8904	23205497	TRANSISTOR, KTA1266 Y/P
Q8911	23205499	TRANSISTOR, KTC3198 Y/P
Q8912	23205499	TRANSISTOR, KTC3198 Y/P
Q8930	23009998	IC, BA00JC5WT-V5
Q8940	23009998	IC, BA00JC5WT-V5
Q8950	23085503	IC, OPE AMP, TA75358P
QA81	23205329	TRANSISTOR, RN1404(F)
QA82	23205329	TRANSISTOR, RN1404(F)
QA83	23205329	TRANSISTOR, RN1404(F)
QA84	23205329	TRANSISTOR, RN1404(F)
QA85	23205329	TRANSISTOR, RN1404(F)
QA86	23205329	TRANSISTOR, RN1404(F)
QA87	23205329	TRANSISTOR, RN1404(F)
QA88	23205329	TRANSISTOR, RN1404(F)
QA91	23085674	IC, QT240-ISS-G-CA
QA92	23085674	IC, QT240-ISS-G-CA
QA93	23085731	IC, +4.2V 2% REG. SOT-23-5 R1121N421B-TR-FA
QA94	23085067	IC, R1121N331B-TR-FA
QB81	23205446	TRANSISTOR, 2SC2412K, Q T146
QB83	23085867	IC, DUAL COMPARATOR BA10393F-E2
QB84	23205446	TRANSISTOR, 2SC2412K, Q T146
QS01	23009916	IC, MM1631AJBE
QS02	23205506	TRANSISTOR, 2SC4081 Q
QS03	23205506	TRANSISTOR, 2SC4081 Q
QS04	23205506	TRANSISTOR, 2SC4081 Q
QS05	23205428	TRANSISTOR, KRA104S/P
QS06	23205424	TRANSISTOR, KTC2875B/P
QS07	23205424	TRANSISTOR, KTC2875B/P
QV01	23009940	IC, MM1630AQ
QV004	23205506	TRANSISTOR, 2SC4081 Q
QV005	23205506	TRANSISTOR, 2SC4081 Q
QV006	23205506	TRANSISTOR, 2SC4081 Q
QV007	23205506	TRANSISTOR, 2SC4081 Q
QV008	23205506	TRANSISTOR, 2SC4081 Q
QV009	23205305	TRANSISTOR, 2SC4667-O(F)
QV48	23205499	TRANSISTOR, KTC3198 Y/P
QV91	23205507	TRANSISTOR, 2SA1576A Q
QY100	23085570	IC, TC90A45F
QY101	23205506	TRANSISTOR, 2SC4081 Q
QY102	23205506	TRANSISTOR, 2SC4081 Q
QY103	23205507	TRANSISTOR, 2SA1576A Q
QY160	23205347	TRANSISTOR, KTC4075Y/P
QY501	23009929	IC, TA1383FG(DRY,EL)
QY502	23205305	TRANSISTOR, 2SC4667-O(F)
QY503	23205507	TRANSISTOR, 2SA1576A Q
QY504	23205507	TRANSISTOR, 2SA1576A Q
QY506	23205506	TRANSISTOR, 2SC4081 Q
QY507	23205506	TRANSISTOR, 2SC4081 Q

Location No.	Parts No.	Description
QY508	23205506	TRANSISTOR, 2SC4081 Q
QY509	23205506	TRANSISTOR, 2SC4081 Q
QY511	23205507	TRANSISTOR, 2SA1576A Q
QY512	23205507	TRANSISTOR, 2SA1576A Q
QY513	23205507	TRANSISTOR, 2SA1576A Q
QY514	23205507	TRANSISTOR, 2SA1576A Q
QY515	23205507	TRANSISTOR, 2SA1576A Q
QY516	23205507	TRANSISTOR, 2SA1576A Q
QY518	23205506	TRANSISTOR, 2SC4081 Q
QY522	23205506	TRANSISTOR, 2SC4081 Q
D601	23357703	DIODE, 1SS355
D602	23357703	DIODE, 1SS355
D603	23357703	DIODE, 1SS355
D604	23357703	DIODE, 1SS355
D605	23357703	DIODE, 1SS355
D606	23357703	DIODE, 1SS355
D607	23357703	DIODE, 1SS355
D608	23357703	DIODE, 1SS355
D609	23357703	DIODE, 1SS355
D611	23357703	DIODE, 1SS355
D612	23357703	DIODE, 1SS355
D613	23357703	DIODE, 1SS355
D614	23357703	DIODE, 1SS355
D615	23357703	DIODE, 1SS355
D616	23357703	DIODE, 1SS355
D617	23357703	DIODE, 1SS355
D628	23357771	DIODE, ZENER, MA8120-M
D801	23357712	DIODE, D5SB60, 4009 F05
D840	23362046	DIODE, LN1WBA60 4101
D841	23357838	DIODE, ZENER, MTZJ5.6C
D842	23357830	DIODE, ZENER, MTZJ4.7A
D843	23357366	DIODE, FR105-B5
D844	23357838	DIODE, ZENER, MTZJ5.6C
D845	23357697	DIODE, 1SS133
D846	23357684	DIODE, ZENER, RD3.0ESA B2
D847	23357684	DIODE, ZENER, RD3.0ESA B2
D848	23357697	DIODE, 1SS133
D849	23357697	DIODE, 1SS133
D850	23357622	DIODE, ZENER, RD11ESA B3
D861	23357837	DIODE, ZENER, MTZJ5.6B
D863	23357697	DIODE, 1SS133
D864	23357366	DIODE, FR105-B5
D865	23357697	DIODE, 1SS133
D866	23357709	DIODE, RU1P
D867	23357900	DIODE, ZENER, MTZJ33B
D883	23357702	DIODE, FML-G12S
D884	23357366	DIODE, FR105-B5
D885	23357860	DIODE, RL2Z
D886	23357408	DIODE, FMX-12S(023-108)
D887	23357911	DIODE, FMB-26L
D888	23362113	DIODE, FML-G22S
D894	23357841	DIODE, ZENER, MTZJ6.8A
D895	23357841	DIODE, ZENER, MTZJ6.8A
D896	23357841	DIODE, ZENER, MTZJ6.8A
D897	23357841	DIODE, ZENER, MTZJ6.8A
D898	23357841	DIODE, ZENER, MTZJ6.8A
△ D899	76019485	VARISTOR, TNR10V431K
D8200	23357697	DIODE, 1SS133
D8210	23357519	DIODE, RK44,
D8211	23357831	DIODE, ZENER, MTZJ4.7B
D8902	23357697	DIODE, 1SS133
D8903	23357697	DIODE, 1SS133
D8904	23357838	DIODE, ZENER, MTZJ5.6C
D8905	23357838	DIODE, ZENER, MTZJ5.6C
D8911	23357838	DIODE, ZENER, MTZJ5.6C
D8912	23357838	DIODE, ZENER, MTZJ5.6C
D8913	23357838	DIODE, ZENER, MTZJ5.6C
D8914	23357697	DIODE, 1SS133
D8915	23357697	DIODE, 1SS133
D8922	23357639	DIODE, ZENER, RD5.6ESA B1
D8930	23357697	DIODE, 1SS133
D8931	23357697	DIODE, 1SS133
D8940	23357697	DIODE, 1SS133
D8941	23357697	DIODE, 1SS133
D8950	23357637	DIODE, ZENER, RD5.6ESA B3
D8951	23357637	DIODE, ZENER, RD5.6ESA B3

Location No.	Parts No.	Description
DA91	23357406	DIODE, ZENER, UDZS5.6B
DA92	23357406	DIODE, ZENER, UDZS5.6B
DB03	23358615	DIODE, LED INFRARED, SIR-56SB3F
DB81	23358584	DIODE, LED, SML-811UTT86
DB82	23358585	LED, LAMP, SML-810MTT86
DV07	23357751	DIODE, ZENER, MA8068-M
DV14	23357751	DIODE, ZENER, MA8068-M
KB01	23000852	REMOCON RECEIVER, PIC-37043TE2
MISCELLANEOUS		
A305	23717197	SCREW, THUMB SCREW
A306	23717198	SCREW, THUMB SCREW RETAINER
A516	23717192	SCREW, SCREW, AV BOARD
B112	23059129	PIECE COVER
B209	23738088	SCREW, BTBW3X12ECO
B214	23965241	TAPE, CC #12 10MM L30M
B215	23965241	TAPE, CC #12 10MM L30M
B231	23738088	SCREW, BTBW3X12ECO
B235	23845856	CLAMP, WIRE, POF COAT) L=70MM
BB10	23713014	PLUG, B-B 16P 1.5
BB11	23713013	SOCKET, B-B 16P 1.5
BB20	23713014	PLUG, B-B 16P 1.5
BB21	23713013	SOCKET, B-B 16P 1.5
BB70	23713810	PLUG, TAC-A46P-B1
BB71	23903245	SOCKET, B-B 46P, TAC-A46X-B1
△ F801	23144319	FUSE, CARTRIDGE, 125V 8A, 5.2X20
F801A	23165433	FUSE HOLDER, 5.2 SOC
△ F840	23144704	FUSE, AXIAL 125V 200MA
△ F860	23144714	FUSE, AXIAL 125V 4.0A
△ F880	23144714	FUSE, AXIAL 125V 4.0A
△ F881	23144706	FUSE, AXIAL 125V 500MA
△ F882	23144714	FUSE, AXIAL 125V 4.0A
△ F883	23144715	FUSE, AXIAL 125V 5.0A
△ F884	23144715	FUSE, AXIAL 125V 5.0A
△ F899	23144326	FUSE, CARTRIDGE, 250V 2A, 5.2X20
F899A	23165433	FUSE HOLDER, 5.2 SOC
△ F8210	23144709	FUSE, AXIAL 125V 1.5A
H002	23148378	IF MODULE, US BUFFER 6M TRAP, MVUS51A
H003	23124099	ANTENNA SWITCH, RSU135X1, 2I3O BUNPAI US
H003A	23747055	NUT, F-CONNECTOR 2H BS
J601A	23171400	WIRE, PVC, SOLDER-PLATED 300V 7/16 BRN UL CSA
JR001	23103239	INDUCTOR, BEAD, TEM2143AD
JR002	23103239	INDUCTOR, BEAD, TEM2143AD
MA01	23389271	CABLE, FFC P1.25-15-98
MV01	23368931	CABLE, MDR 26P 300MM 3M 79162-26M-030-011F
MV04	23389270	CABLE, FFC P1.25-26-140
MX18	23389272	CABLE, FFC P1.25-11-365
MX19	23389273	CABLE, FFC P1.25-17-410
P105	23713755	PLUG, 4P 2.5MM G, B4B-EH-F1-TV4
△ P800	23713702	PLUG, 2P 11.88MM W VT
△ P801	23372117	POWER CORD, U/C 125V10A HSV 5 CMC-02P 5
P805	23164965	CONNECTOR, PLUG 4P, W-P3504-#02
P811A	23713713	PLUG, 2P 3.96MM VH
P891	23713759	PLUG, 8P 2.5MM G, B8B-EH-F1-TV4
P892	23713764	PLUG, 13P
P901	23713754	PLUG, 3P 2.5MM G, B3B-EH-F1-TV4
P902A	23164563	CONNECTOR, PLUG 3P
P903	23713755	PLUG, 4P 2.5MM G, B4B-EH-F1-TV4
P906	23713761	PLUG, NP 2.5MM G, B10B-EH-F1A
P907	23713763	PLUG, NP 2.5MM G, B12B-EH-F1A
PA01	23713240	CONNECTOR, 15FE-BT-VK-N JST
PB22	23713755	PLUG, 4P 2.5MM G, B4B-EH-F1-TV4
PJ60	23713756	PLUG, 5P 2.5MM G, B5B-EH-F1-TV4
PJ61	23713762	PLUG, NP 2.5MM G, B11B-EH-F1A
PJ63	23713756	PLUG, 5P 2.5MM G, B5B-EH-F1-TV4
PJ64	23713757	PLUG, 6P 2.5MM G, B6B-EH-F1-TV4
PV01	23023311	JACK, PIN 2S6P, LAP5030-0111GC
PV02	23023205	JACK, PIN 10P SMK KARI2 @U103
	23023184	JACK, 1S3P, LAP5100-1502F @UV03
PV03	23023211	JACK, PIN 7P SMK KARI04
PV04	23713282	CONNECTOR, 26FE-ST-VK-N
PV13	23713760	PLUG, NP 2.5MM G, B9B-EH-F1A
PV14	23713781	PLUG, 8P 2.5MM W, S8B-EH
PX18	23713270	CONNECTOR, 11FE-ST-VK-N
PX19	23713110	CONNECTOR, FE-ST-VK-N 17P JST
Q825B	23738088	SCREW, BTBW3X12ECO

Location No.	Parts No.	Description
Q893B	23717241	SCREW, BITTB3X8ECO
Q894B	23717241	SCREW, BITTB3X8ECO
△ S810	23344522	SWITCH, SPVF11
△ SR81	23146588	RELAY, DLS5D1-O(M) 0.15W
△ SR82	23146584	RELAY, DC12V, TV5, DG-3
W661	23351244	SPEAKER, SPBOX(L) 8-OHM 20W SPK-1455AM
W662	23351245	SPEAKER, SPBOX(R) 8-OHM 20W SPK-1456AM
XY501	23153607	CRYSTAL, 3.58MHZ
XY502	23153721	CERAMIC RESONATOR, 503KHZ
PC BOARD ASSEMBLIES		
* U101	23764145	PC BOARD ASSY, IF AUDIO ACIN PU PD1775D
* U103	23764144	PC BOARD ASSY, BACK AV PU PD1774C
* U802	23764201	PC BOARD ASSY, MAIN POWER PU PD2128A-1
* UA02	23764202	PC BOARD ASSY, REMOTE SENS PU PD2128A-3
* UA03	23764203	PC BOARD ASSY, DOOR SW PU PD2128A-4
* UA06	23764199	PC BOARD ASSY, FRONT KEY, PD2072H
* UD02 #1	23148438	PC BOARD ASSY SCALER, B910PD2208A1
* #2	23148439	PC BOARD ASSY SCALER, B910PD2208B1
* UV02	23148418	SCAN CONVERTER MODULE, MHDM01A
* UV03	23764204	PC BOARD ASSY, FRONT AV PU PD2128A-2
TUNER		
△ H001	23321482	TUNER, US181CH IIC PH 5V PANA ELA52LX5
△ HY01	23321480	TUNER, TIF US IIC PH 181CH 5V ENG36A18GF
ACCESSORIES		
A701 #1	23067697	CARTON
#2	23067698	CARTON
A703 #1	23946771	PACKING, TOP PACKING
#2	23946772	PACKING, TOP PACKING
A708 #1	23946768	PACKING, BOTTOM PACKING
#2	23946769	PACKING, BOTTOM PACKING
A709 #1	23067694	CARTON, BASE TRAY
#2	23067695	CARTON, BASE TRAY
A710 #1	23946774	PACKING, SUPPORT POST
#2	23946775	PACKING, SUPPORT POST
A721	23943628	PLYETHLENE COVERING 46GM88T
△ K912	23306617	REMOCON HAND UNIT IR, CTVUSA CT-90159
△ Y101E	23566609	OWNERS MANUAL, ENGLISH
△ Y101F	23566610	OWNERS MANUAL, FRENCH
Y102	23589650	SHEET, IMPORTANT NOTES
CABINET PARTS		
△ A025	23532769	COVER, LAMP TUNNEL PURCHASE ASY
△ A026	23428292	DOOR, DOOR LAMP PURCHASE ASSY
△ A101	23533280	COVER, BASE PURCHASE ASSEY
△ A201 #1	23533355	COVER, BEZEL PURCHASE ASSY
#2	23533345	COVER, BEZEL PURCHASE ASM
A204 #1	23532684	COVER, BACK COVER
#2	23532763	COVER, BACK COVER
△ A205 #1	23532782	COVER, BACKCOVER PURCHASE ASSY
#2	23532784	COVER, BACKCOVER PURCHASE ASSY
A215	23940083	PIECE, PIECE ENCLOSURE,DLE
A220	23451976	PUSH CATCH, CLICK
△ A222 #1	23532770	COVER, PEDESTAL PURCHASE ASSY
#2	23532885	COVER, PEDESTAL ASSY
A225	23940084	PIECE, STRIKER
A227 #1	23433349	DECORATIVE, CTRL PANEL TRIM
#2	23433348	DECORATIVE, CTRL PANEL TRIM
A231 #2	23940100	PIECE, PIECE SIDE RIGHT
A232 #2	23940099	PIECE, PIECE SIDE LEFT
△ A271 #1	23405474	OPTICAL ENGINE, LV-672 TB 0B
#2	23405476	OPTICAL ENGINE, LV-672 TB 0D
A278	23084267	BRACKET, SPEED CLIP
A333	23940463	PIECE, AV MOUNT PURCHASE ASY
△ A401	23533281	COVER, REAR COVER PURCHASE
A421	23532738	COVER, REAR COVER,DLE
A422	23084729	VENT, REAR DLE
E998Z	23311153	EXCHANGE LAMP, PJ-D95-LMP
K501 #1	23311133	SCREEN, 52K5M LENTICULAR SHEET
#2	23311137	SCREEN, 62K5M LENTICULAR SHEET
K502 #1	23311072	SCREEN, 52K4M FRESNEL SHEET
#2	23311081	SCREEN, 62K4MF FRESNEL SHEET
K601 #1	23405453	MIRROR, 52G4M3
#2	23405455	MIRROR, 62G4M3

Location No.	Parts No.	Description
SK01	23587525	SERVICE KIT, LAMP FAN
SK02	23587526	SERVICE KIT, DMD FAN
SK03	23587527	SERVICE KIT, BALLAST FAN
SK04	23587528	SERVICE KIT, THERMOSTAT
SK06	23587536	SERVICE KIT, B TO F CABLE
SK08	23587538	SERVICE KIT, S TO F CABLE
SK09	23587539	SERVICE KIT, FAN TRANSFER CABLE

BACK AV BOARD PD1774C (U103)
BOTTOM (FOIL) SIDE

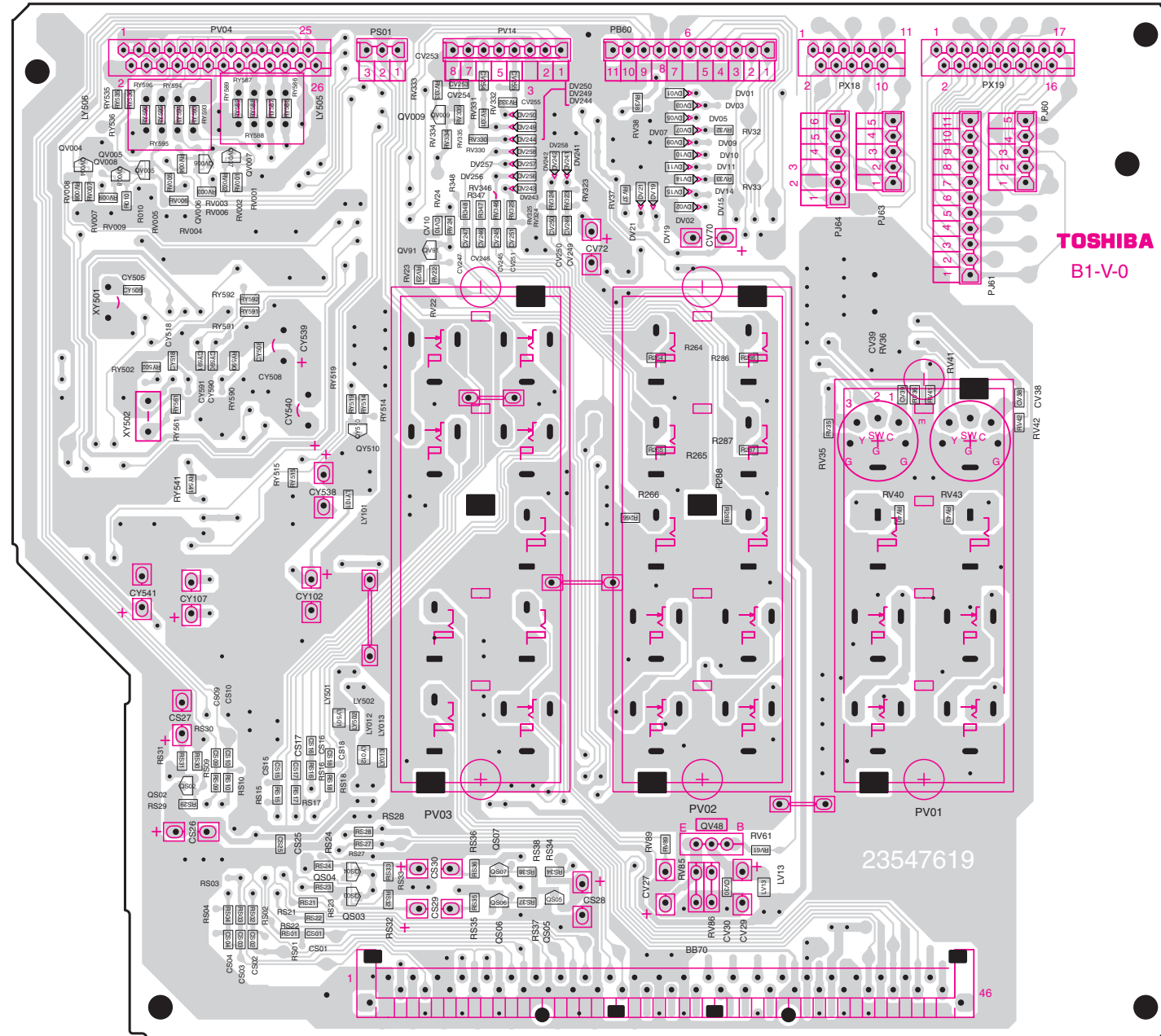

BACK AV BOARD PD1774C (U103)
TOP (COMPONENT) SIDE

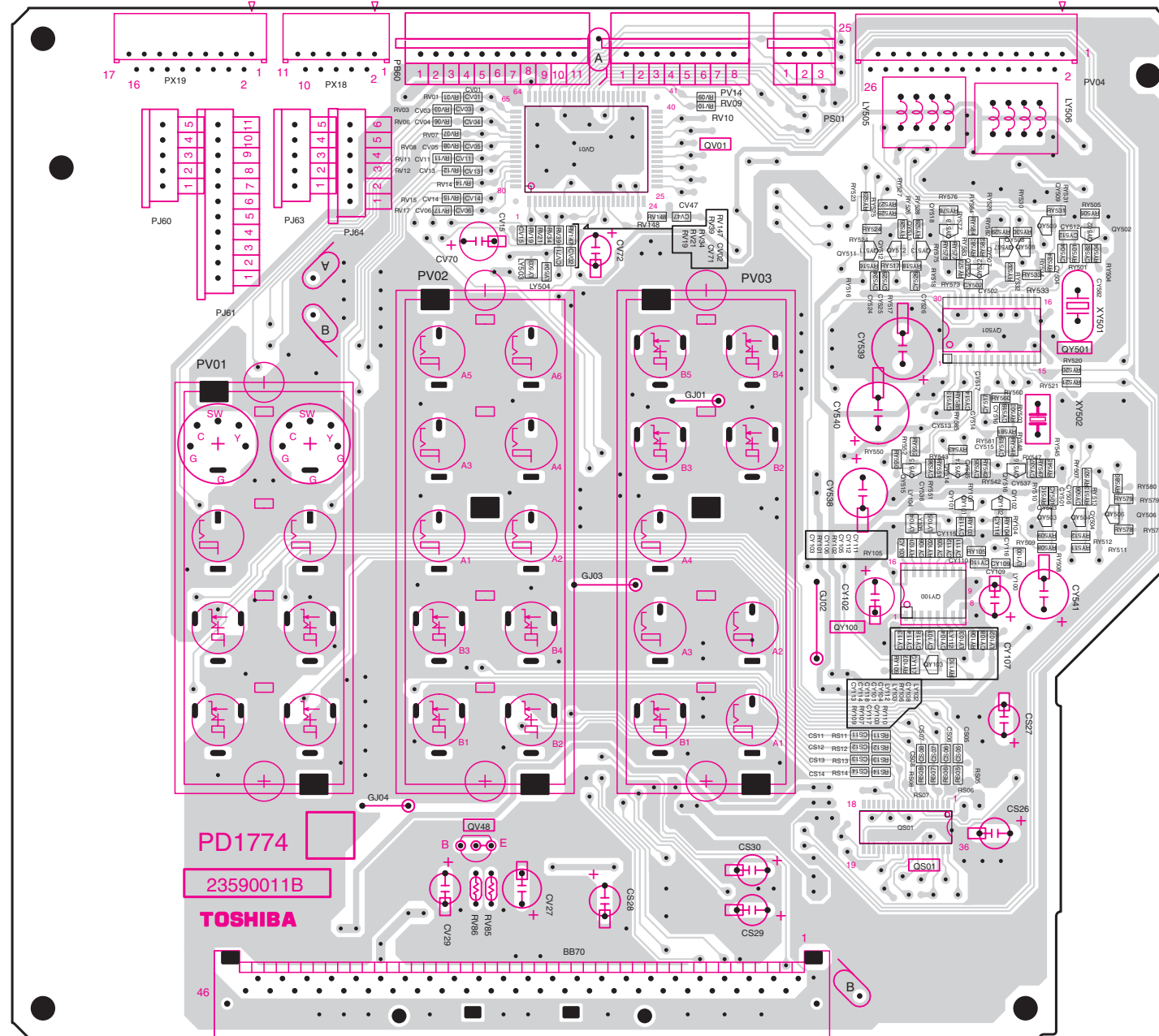

MAIN POWER BOARD PD2128A-1 (U802)
BOTTOM (FOIL) SIDE

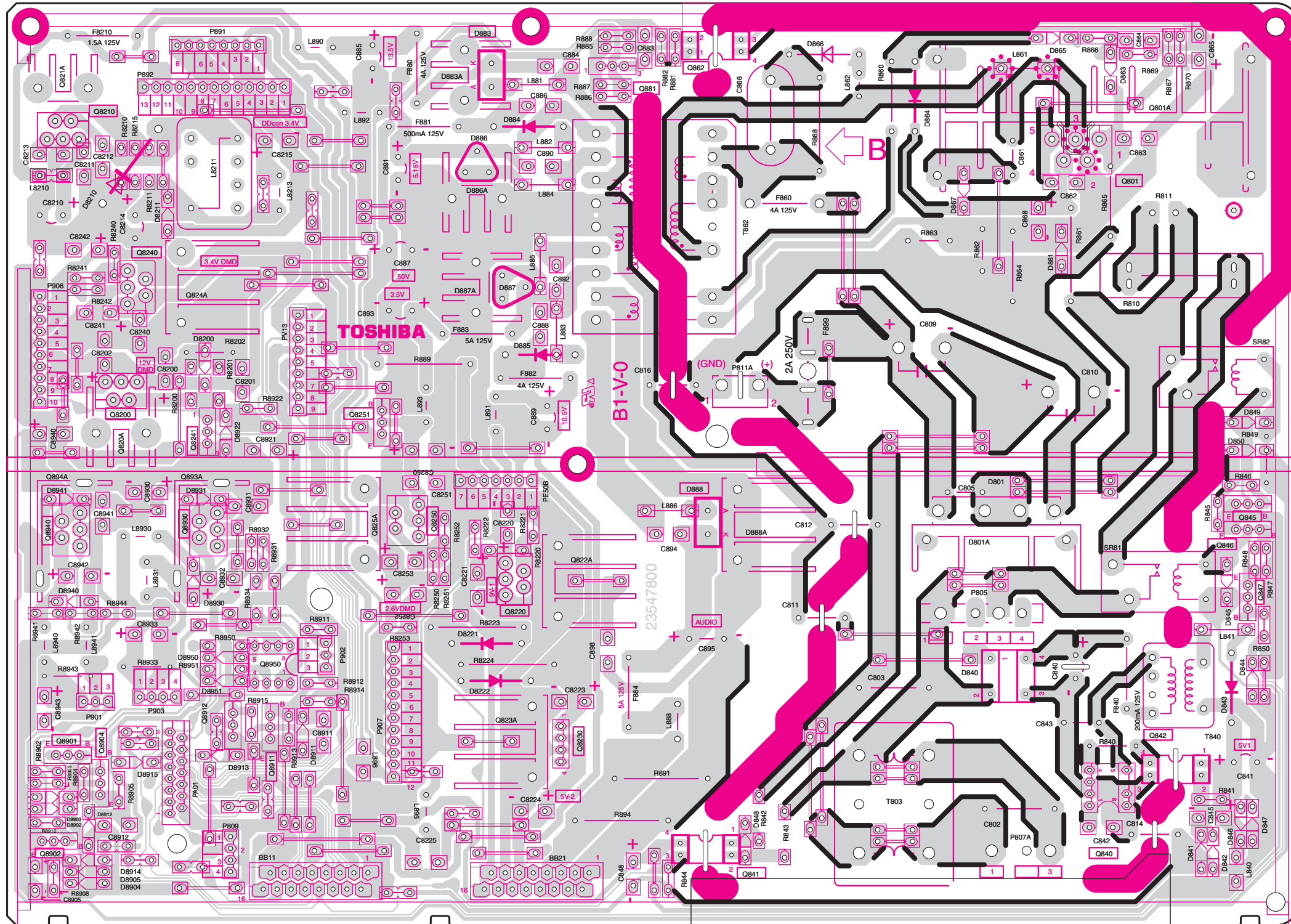

IF AUDIO BOARD PD1775D (U101)
BOTTOM (FOIL) SIDE

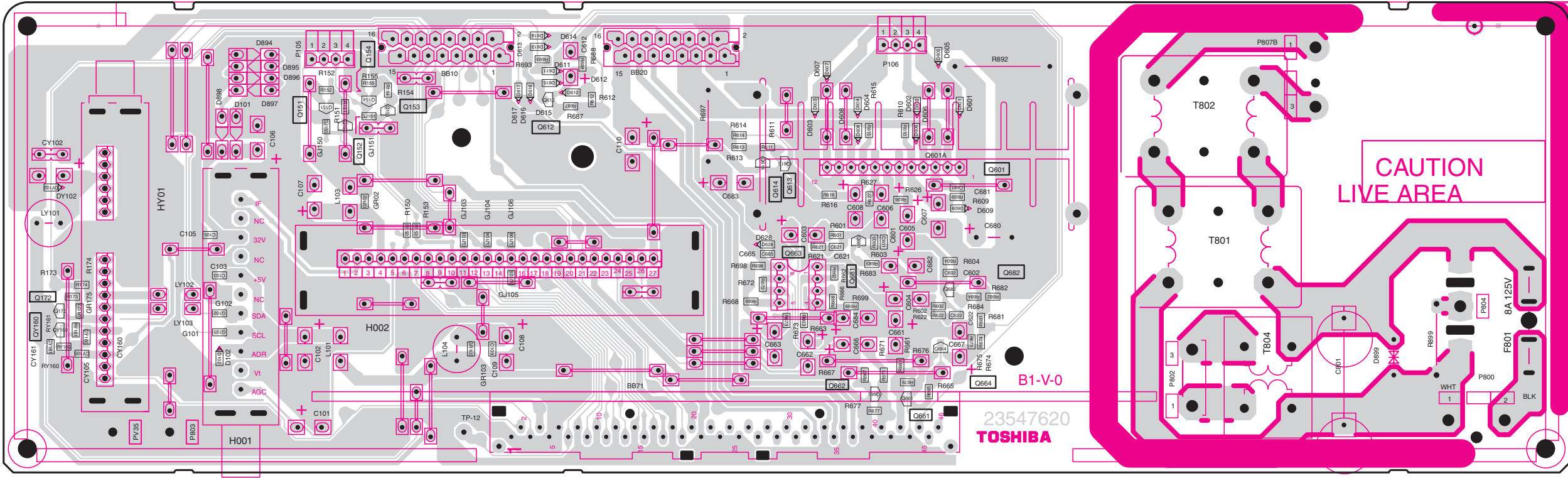

FRONT AV BOARD PD2128A-2 (UV03)
BOTTOM (FOIL) SIDE

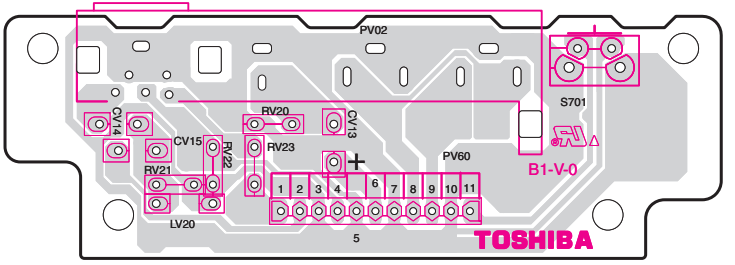

DOOR SWITCH BOARD PD2128A-4 (UA03)
BOTTOM (FOIL) SIDE

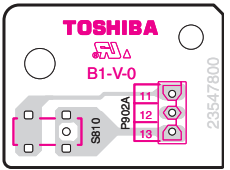

REMOTE SENSOR BOARD PD2128A-3 (UA02)
BOTTOM (FOIL) SIDE

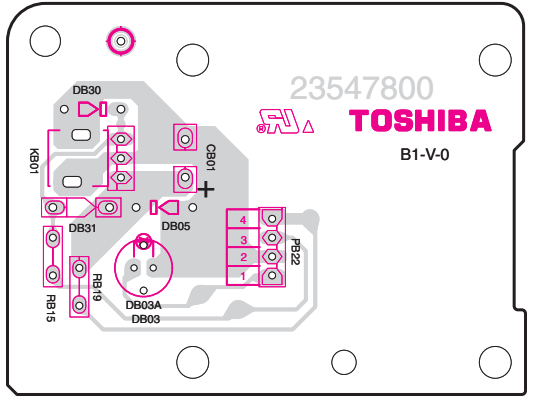

FRONT KEY BOARD PD2072H (UA06)
TOP (COMPONENT) SIDE

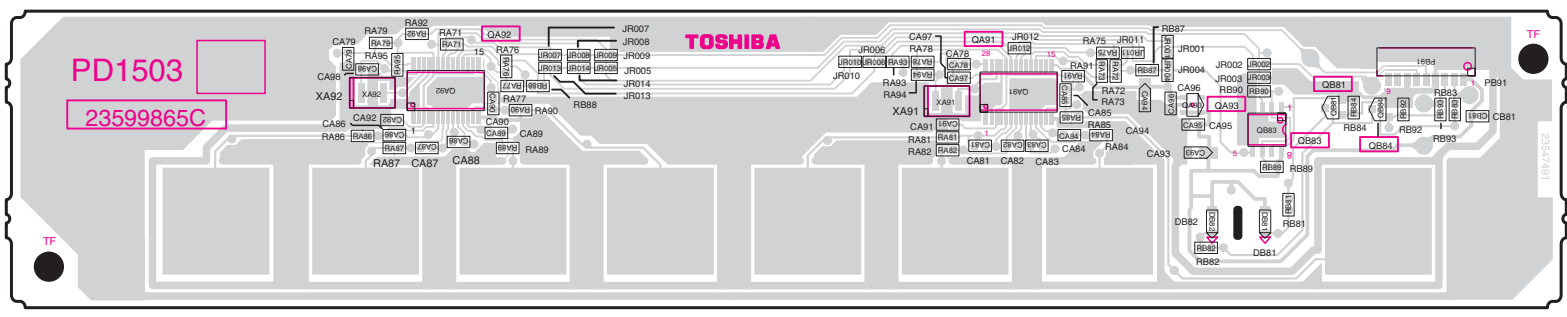

SCALER BOARD PD2208A1 (52HM85) (UD02)
 SCALER BOARD PD2208B1 (62HM85) (UD02)
 BOTTOM (FOIL) SIDE

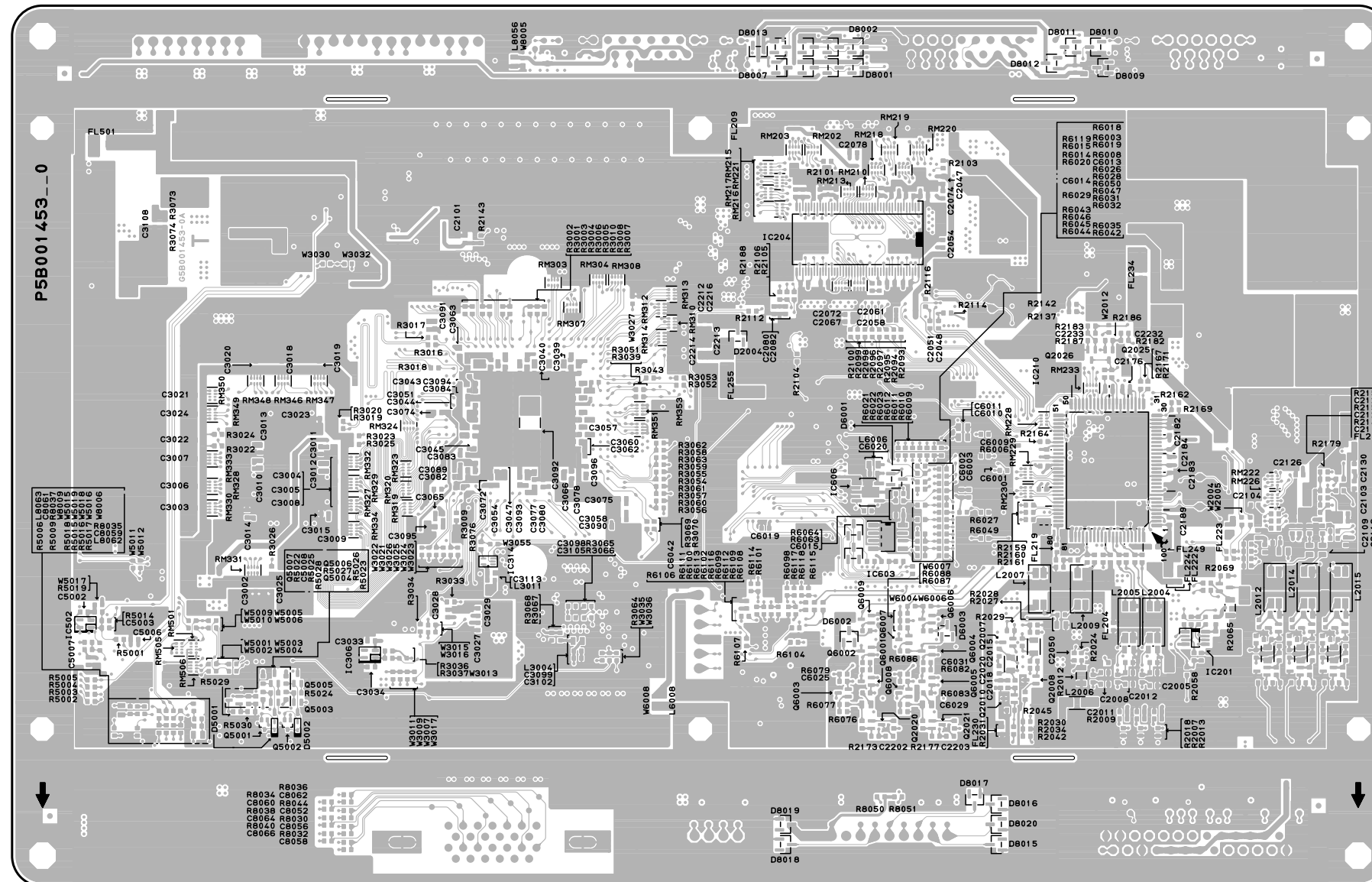

SCALER BOARD PD2208A1 (52HM85) (UD02)
 SCALER BOARD PD2208B1 (62HM85) (UD02)
 TOP (COMPONENT) SIDE

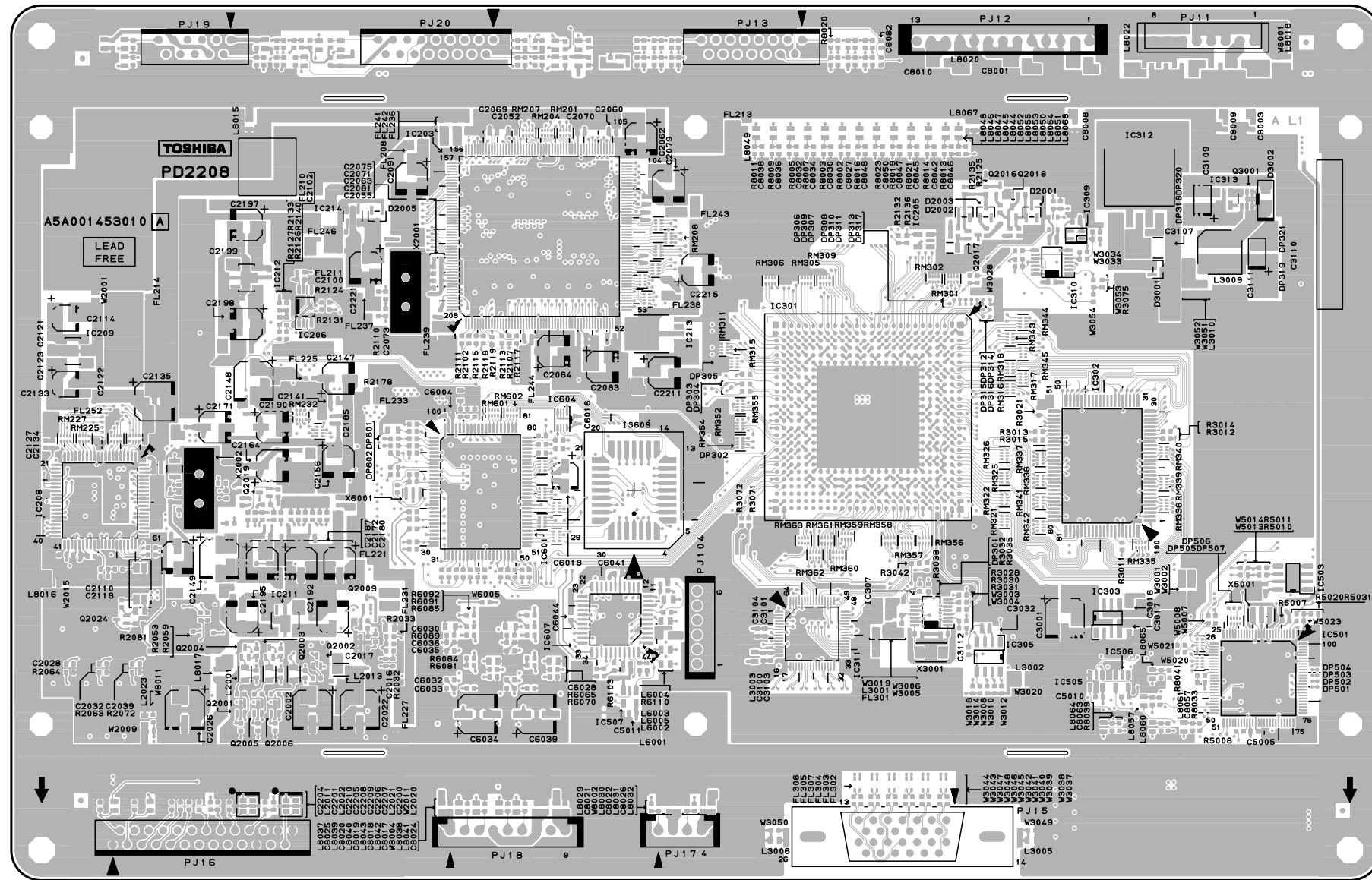

TERMINAL VIEW OF TRANSISTORS

① 2SC5144
2SC5859

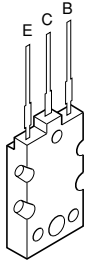

② 2SC3852
2SD1763A
2SC1569
2SC4544
2SA1788
2SA1306
2SA1186A

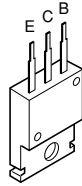

③ 2SC752GTM
2SC2482
2SC2655
2SC4721P

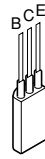

④ 2SC752
2SA562TM
2SA1015
2SC1815
2SC2878
2SC1740S
2SC2120
2SA9335



⑤ 2SA1788

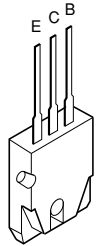

⑥ RN2203
RN2201
RN2004
RN1203
RN1204
RN2204
RN1205
RN1202
RN1201

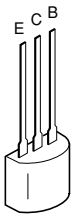

⑦ 2SD1554
2SD2253
2SD1556
2SD2553
2SC5143

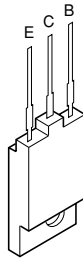

⑧ ON4409

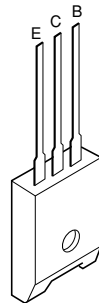



SCHEMATIC DIAGRAM

MODEL : 52HM85/62HM85

WARNING: BEFORE SERVICING THIS CHASSIS, READ THE "X-RAY RADIATION PRECAUTION", "SAFETY PRECAUTION" AND "PRODUCT SAFETY NOTICE" ON THE MANUAL FOR THIS MODEL.

CAUTION: The international hazard symbols " \triangle " in the schematic diagram and the parts list designate components which have special characteristics important for safety and should be replaced only with types identical to those in the original circuit or specified in the parts list. The mounting position of replacements is to be identical with originals. Before replacing any of these components, read carefully the PRODUCT SAFETY NOTICE on the MANUAL for this model. Do not degrade the safety of the receiver through improper servicing.

NOTE:

1. RESISTOR Resistance is shown in ohm [K = 1.000, M = 1.000.000]. All resistors are 1/6W and 5% tolerance carbon resistor, unless otherwise noted as the following marks.
1/2R = Metal or Metal oxide of 1/2 watt 1/2S = Carbon composition of 1/2 watt
1RF = Fuse resistor of 1 watt 10W = Cement of 10 watt
K = $\pm 10\%$ G = $\pm 2\%$ F = $\pm 1\%$
2. CAPACITOR Unless otherwise noted in schematic, all capacitor values less than 1 are expressed in F, and the values more than 1 in pF.
All capacitors are ceramic 50V, unless otherwise noted as the following marks.
 Electrolytic capacitor  Mylar capacitor
3. The parts indicated with " \triangle " have special characteristics, and should be replaced with identical parts only.
4. Voltages read with DIGITAL MULTI-METER from point indicated to chassing ground, using a color bar signal with all controls at normal, line voltage at 220 volts.
5. Waveforms are taken receiving color bar signal with enough sensitivity.
6. Voltage reading shown are nominal values and may vary $\pm 20\%$ except H.V.

■ SCHEMA TIC DIAGRAM STRUCTURE:

BACK AV Circuit	(1/5)	[SHEET - 1/5]	1/52
	(2/5)	[SHEET - 2/5]	2/52
	(3/5)	[SHEET - 3/5]	3/52
	(4/5)	[SHEET - 4/5]	4/52
	(5/5)	[SHEET - 5/5]	5/52
IF AUDIO Circuit	(1/3)	[SHEET - 1/3]	6/12
	(2/3)	[SHEET - 2/3]	7/52
	(3/3)	[SHEET - 3/3]	8/52
F-AV Circuit			9/52
AV_CONNECTOR Circuit.....			10/52
AD_LPF Circuit			11/52
DVCD2_LPF Circuit.....			12/52
DVCD1_LPF Circuit.....			13/52
3chADC HD Circuit			14/52
3chADC MST9883 Circuit.....			15/52
DVCD CSYNCIN Circuit			16/52
DVCD TC90A92AFG Circuit.....			17/52
DVCD POWER Circuit			18/52
GENESIS Circuit	(1/2)	[SHEET - 1/2]	19/52
	(2/2)	[SHEET - 2/2]	20/52
SDRAM Circuit			21/52
GENESIS_POWER Circuit.....			22/52
GENESIS_IIC Circuit.....			23/52
SCALER DIGITAL INPUT Circuit			24/52
SCALER CAPTURE INPUT Circuit			25/52
DDR SDRAM Circuit.....			26/52
SCALER PLL Circuit.....			27/52
OSD for North America Circuit.....			28/52
IIC Circuit.....			29/52
94TB POWER Circuit			30/52
LVDS OUT Circuit.....			31/52
Power (3.3V_2 to 2.5V_DVCC) Circuit			32/52
LVDS OUT CONNECTOR Circuit			33/52
DC/DC CONVERTER Circuit.....			34/52
SUB MICON Circuit	(1/3)	[SHEET - 1/3]	35/52
	(2/3)	[SHEET - 2/3]	36/52
	(3/3)	[SHEET - 3/3]	37/52
OSD MICON 4/4 Circuit.....			38/52
MICON Circuit	(1/3)	[SHEET - 1/3]	39/52
	(2/3)	[SHEET - 2/3]	40/52
	(2/3)	[SHEET - 3/3]	41/52
TV MICON RESET IC & FLASH Circuit			42/52
SYNC_DETECT Circuit			43/52
PLD (US OSD SYNC Generator) Circuit			44/52
POWER_CONNECTOR Circuit.....			45/52
TV MICON CONNECTOR (1) Circuit			46/52
CONNECTOR (TV MICON-POWER BOARD) Circuit			47/52
CONNECTOR (DLF I/F) Circuit.....			48/52
SERVICE CONNECTOR Circuit.....			49/52
Front Key Circuit.....			50/52
MAIN POWER Circuit.....			51/52
AC IN Circuit.....			52/52

CIRCUIT BLOCK DIAGRAM

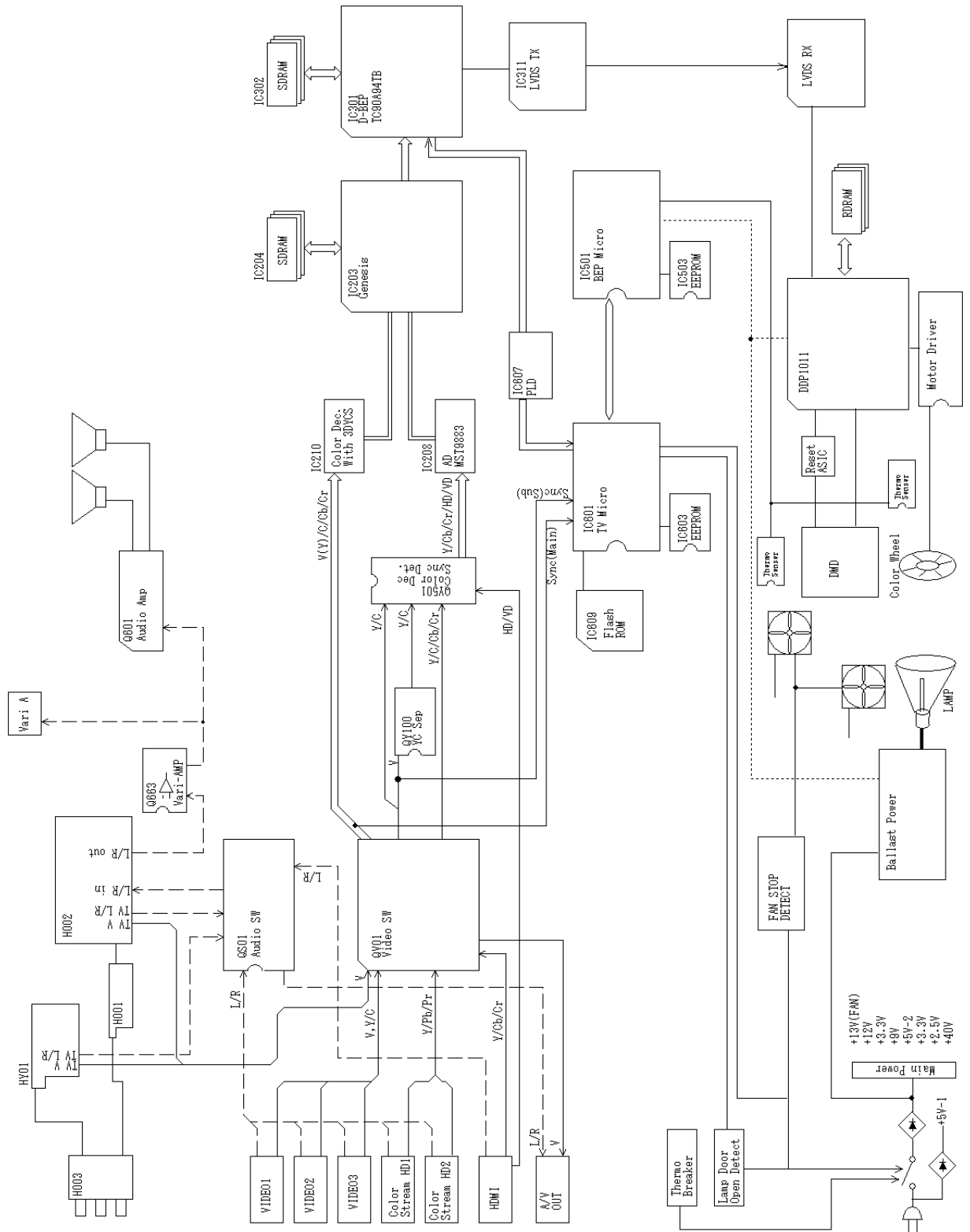

TOSHIBA CORPORATION
1-1, SHIBAURA 1-CHOME, MINATO-KU, TOKYO 105-8001, JAPAN

TOSHIBA

FILE NO. 020-200506

SERVICE MANUAL

Projection Television

52HM85
62HM85



SCHEMATIC DIAGRAM

MODEL : 52HM85/62HM85

WARNING: BEFORE SERVICING THIS CHASSIS, READ THE "X-RAY RADIATION PRECAUTION", "SAFETY PRECAUTION" AND "PRODUCT SAFETY NOTICE" ON THE MANUAL FOR THIS MODEL.

CAUTION: The international hazard symbols " \triangle " in the schematic diagram and the parts list designate components which have special characteristics important for safety and should be replaced only with types identical to those in the original circuit or specified in the parts list. The mounting position of replacements is to be identical with originals. Before replacing any of these components, read carefully the PRODUCT SAFETY NOTICE on the MANUAL for this model. Do not degrade the safety of the receiver through improper servicing.

NOTE:

- RESISTOR** Resistance is shown in ohm [K = 1.000, M = 1.000.000]. All resistors are 1/6W and 5% tolerance carbon resistor, unless otherwise noted as the following marks.
1/2R = Metal or Metal oxide of 1/2 watt 1/2S = Carbon composition of 1/2 watt
1RF = Fuse resistor of 1 watt 10W = Cement of 10 watt
K = $\pm 10\%$ G = $\pm 2\%$ F = $\pm 1\%$
- CAPACITOR** Unless otherwise noted in schematic, all capacitor values less than 1 are expressed in F, and the values more than 1 in pF.
All capacitors are ceramic 50V, unless otherwise noted as the following marks.
 Electrolytic capacitor  Mylar capacitor
- The parts indicated with " \triangle " have special characteristics, and should be replaced with identical parts only.
- Voltages read with DIGITAL MULTI-METER from point indicated to chassing ground, using a color bar signal with all controls at normal, line voltage at 220 volts.
- Waveforms are taken receiving color bar signal with enough sensitivity.
- Voltage reading shown are nominal values and may vary $\pm 20\%$ except H.V.

■ SCHEMA TIC DIAGRAM STRUCTURE:

BACK AV Circuit	(1/5)	[SHEET - 1/5]	1/52
	(2/5)	[SHEET - 2/5]	2/52
	(3/5)	[SHEET - 3/5]	3/52
	(4/5)	[SHEET - 4/5]	4/52
	(5/5)	[SHEET - 5/5]	5/52
IF AUDIO Circuit	(1/3)	[SHEET - 1/3]	6/12
	(2/3)	[SHEET - 2/3]	7/52
	(3/3)	[SHEET - 3/3]	8/52
F-AV Circuit			9/52
AV_CONNECTOR Circuit.....			10/52
AD_LPF Circuit			11/52
DVCD2_LPF Circuit.....			12/52
DVCD1_LPF Circuit.....			13/52
3chADC HD Circuit			14/52
3chADC MST9883 Circuit.....			15/52
DVCD CSYNCIN Circuit			16/52
DVCD TC90A92AFG Circuit.....			17/52
DVCD POWER Circuit			18/52
GENESIS Circuit	(1/2)	[SHEET - 1/2]	19/52
	(2/2)	[SHEET - 2/2]	20/52
SDRAM Circuit			21/52
GENESIS_POWER Circuit.....			22/52
GENESIS_IIC Circuit.....			23/52
SCALER DIGITAL INPUT Circuit			24/52
SCALER CAPTURE INPUT Circuit			25/52
DDR SDRAM Circuit.....			26/52
SCALER PLL Circuit.....			27/52
OSD for North America Circuit.....			28/52
IIC Circuit.....			29/52
94TB POWER Circuit			30/52
LVDS OUT Circuit.....			31/52
Power (3.3V_2 to 2.5V_DVCC) Circuit.....			32/52
LVDS OUT CONNECTOR Circuit			33/52
DC/DC CONVERTER Circuit.....			34/52
SUB MICON Circuit	(1/3)	[SHEET - 1/3]	35/52
	(2/3)	[SHEET - 2/3]	36/52
	(3/3)	[SHEET - 3/3]	37/52
OSD MICON 4/4 Circuit.....			38/52
MICON Circuit	(1/3)	[SHEET - 1/3]	39/52
	(2/3)	[SHEET - 2/3]	40/52
	(2/3)	[SHEET - 3/3]	41/52
TV MICON RESET IC & FLASH Circuit			42/52
SYNC_DETECT Circuit			43/52
PLD (US OSD SYNC Generator) Circuit			44/52
POWER_CONNECTOR Circuit.....			45/52
TV MICON CONNECTOR (1) Circuit			46/52
CONNECTOR (TV MICON-POWER BOARD) Circuit			47/52
CONNECTOR (DLF I/F) Circuit.....			48/52
SERVICE CONNECTOR Circuit.....			49/52
Front Key Circuit.....			50/52
MAIN POWER Circuit.....			51/52
AC IN Circuit.....			52/52

CIRCUIT BLOCK DIAGRAM

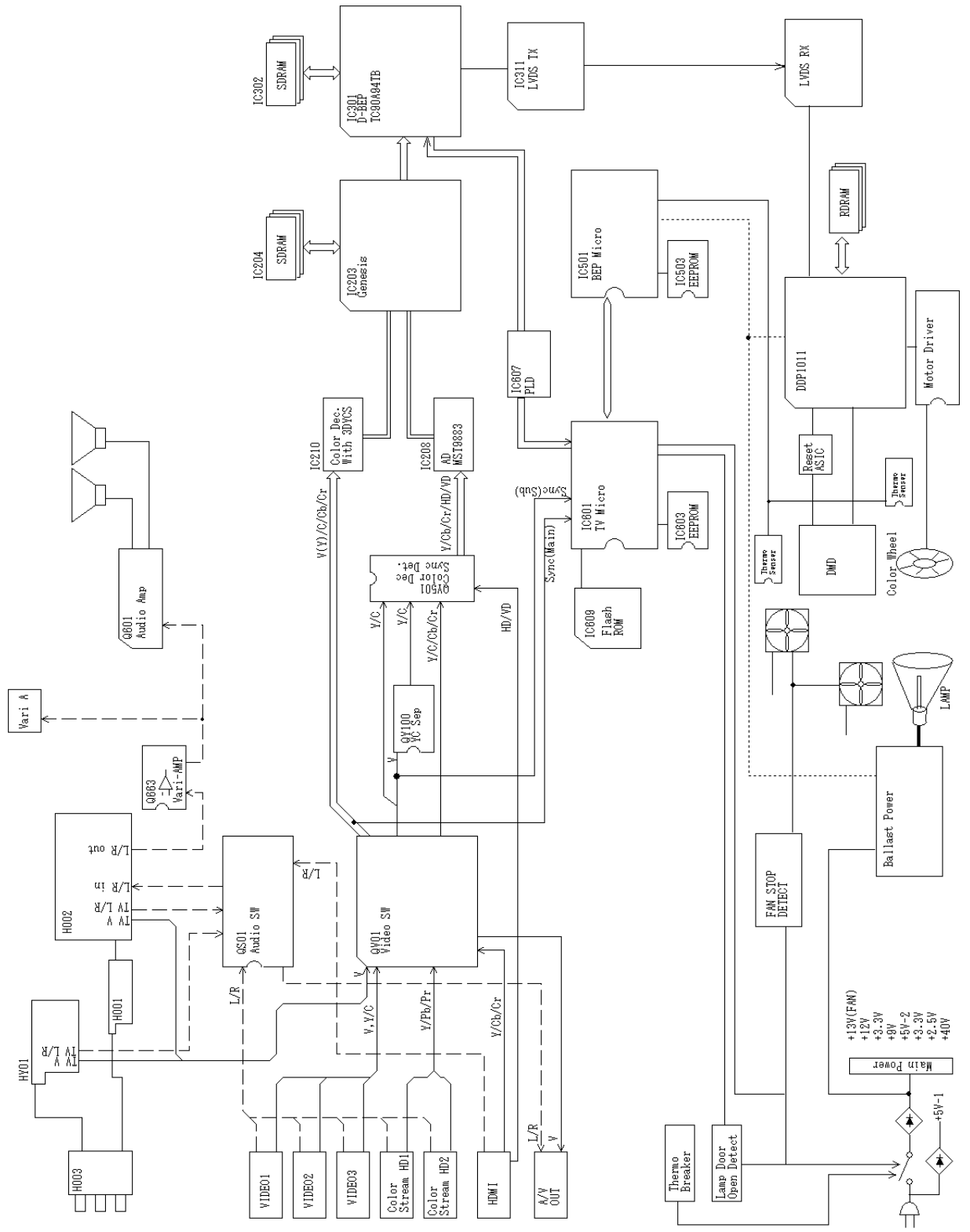

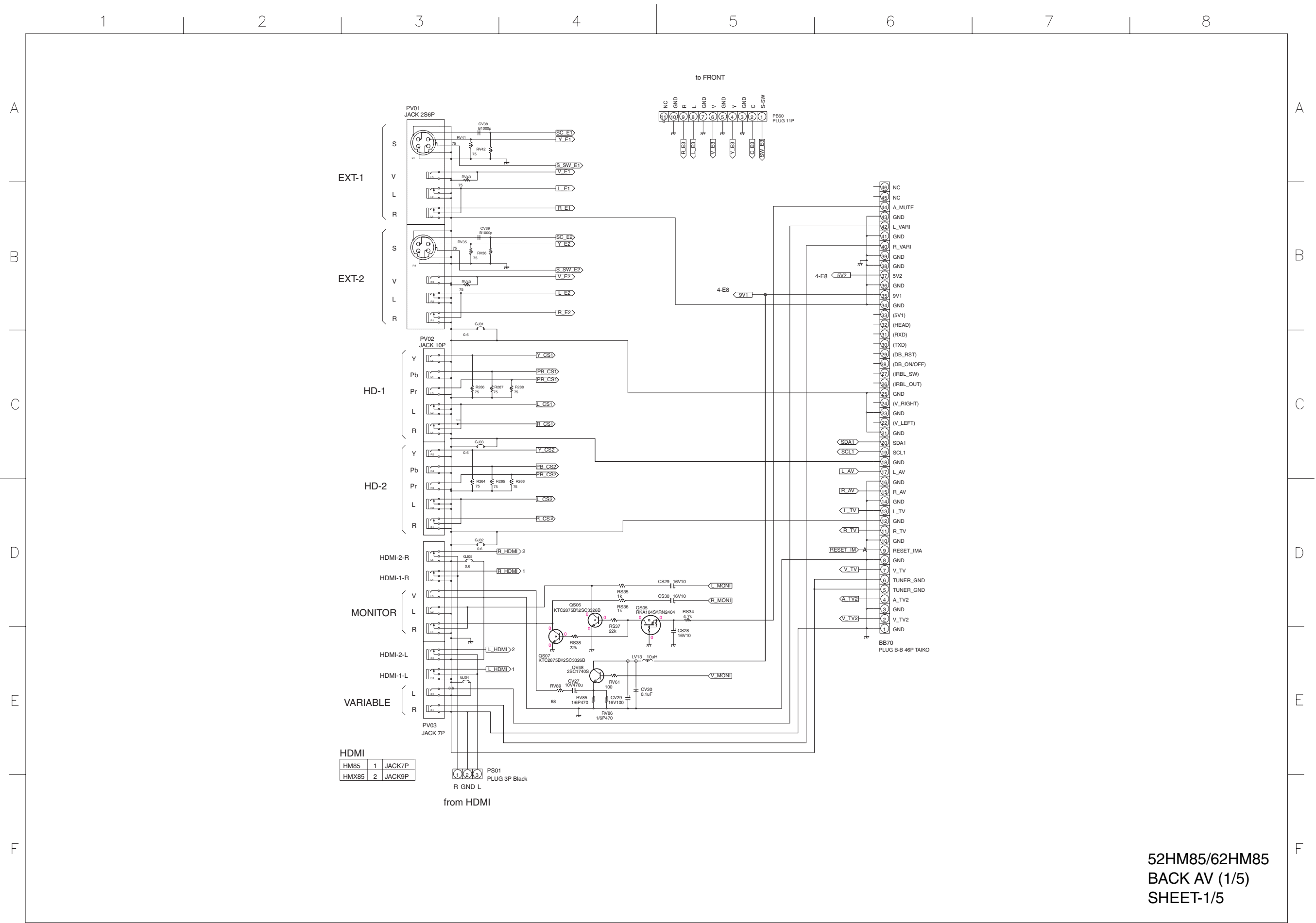

HDMI	
HMB5	1 JACK7P
HMX85	2 JACK9P

52HM85/62HM85
 BACK AV (1/5)
 SHEET-1/5

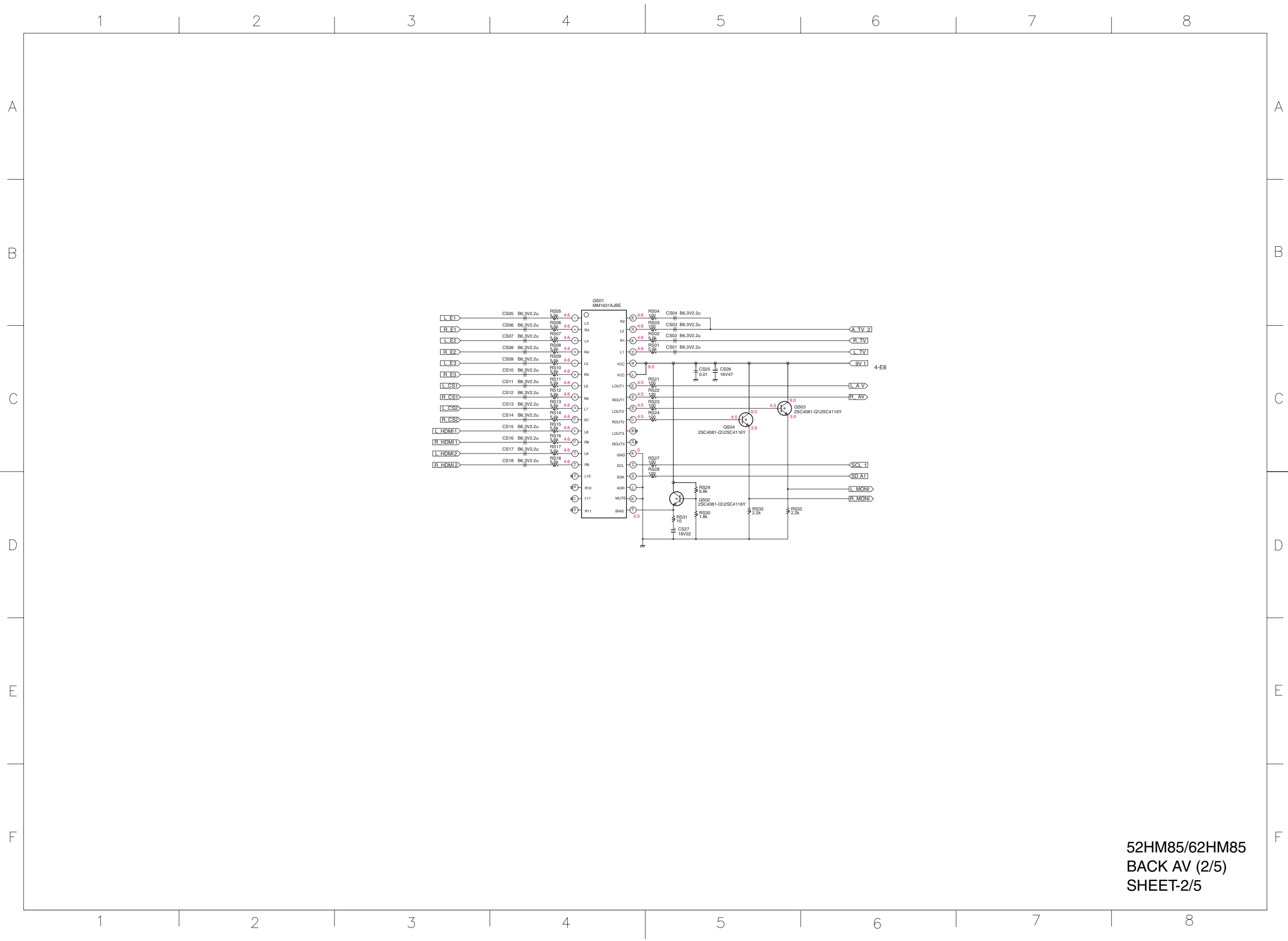

52HM85/62HM85
 BACK AV (2/5)
 SHEET-2/5

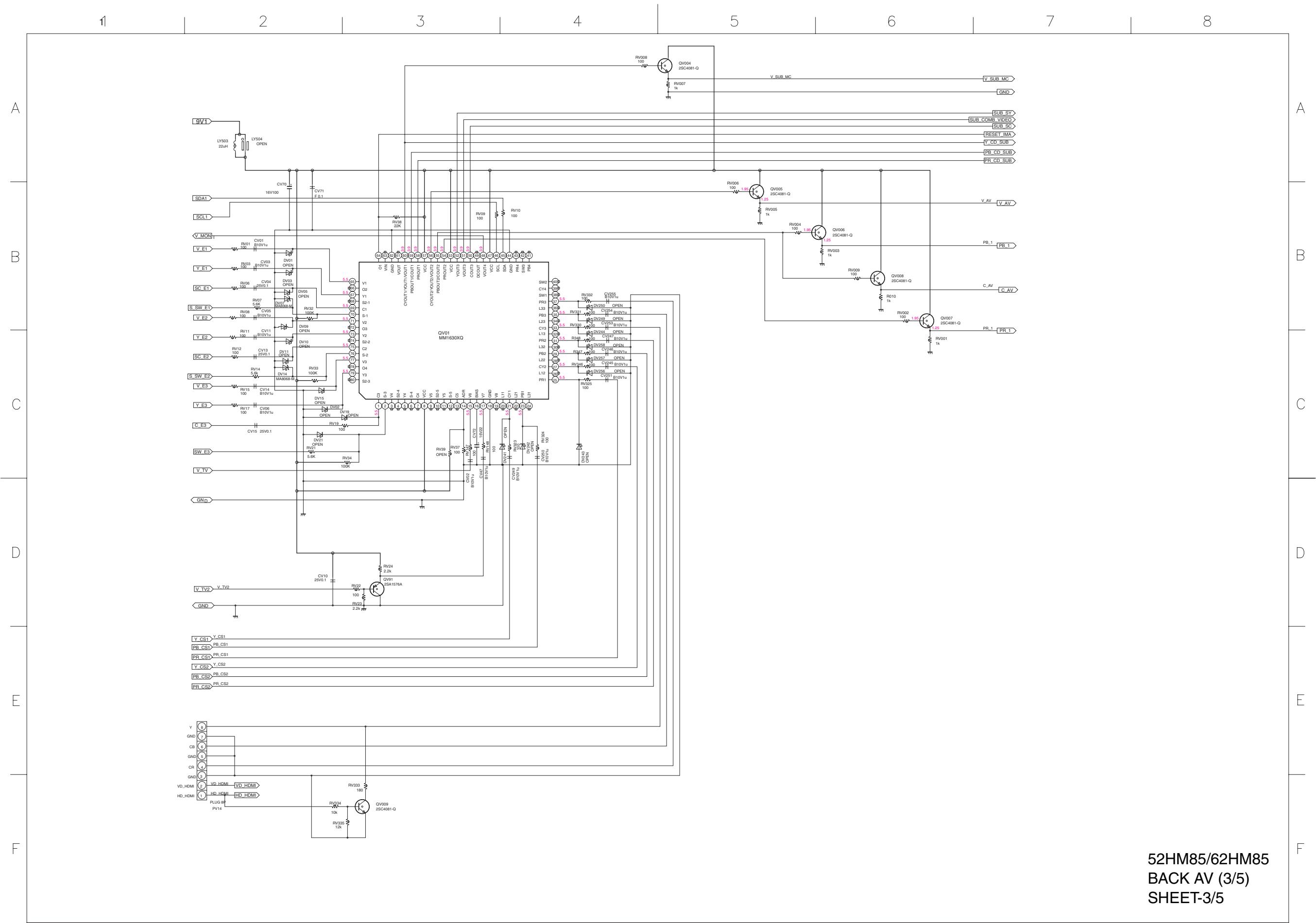

52HM85/62HM85
 BACK AV (3/5)
 SHEET-3/5

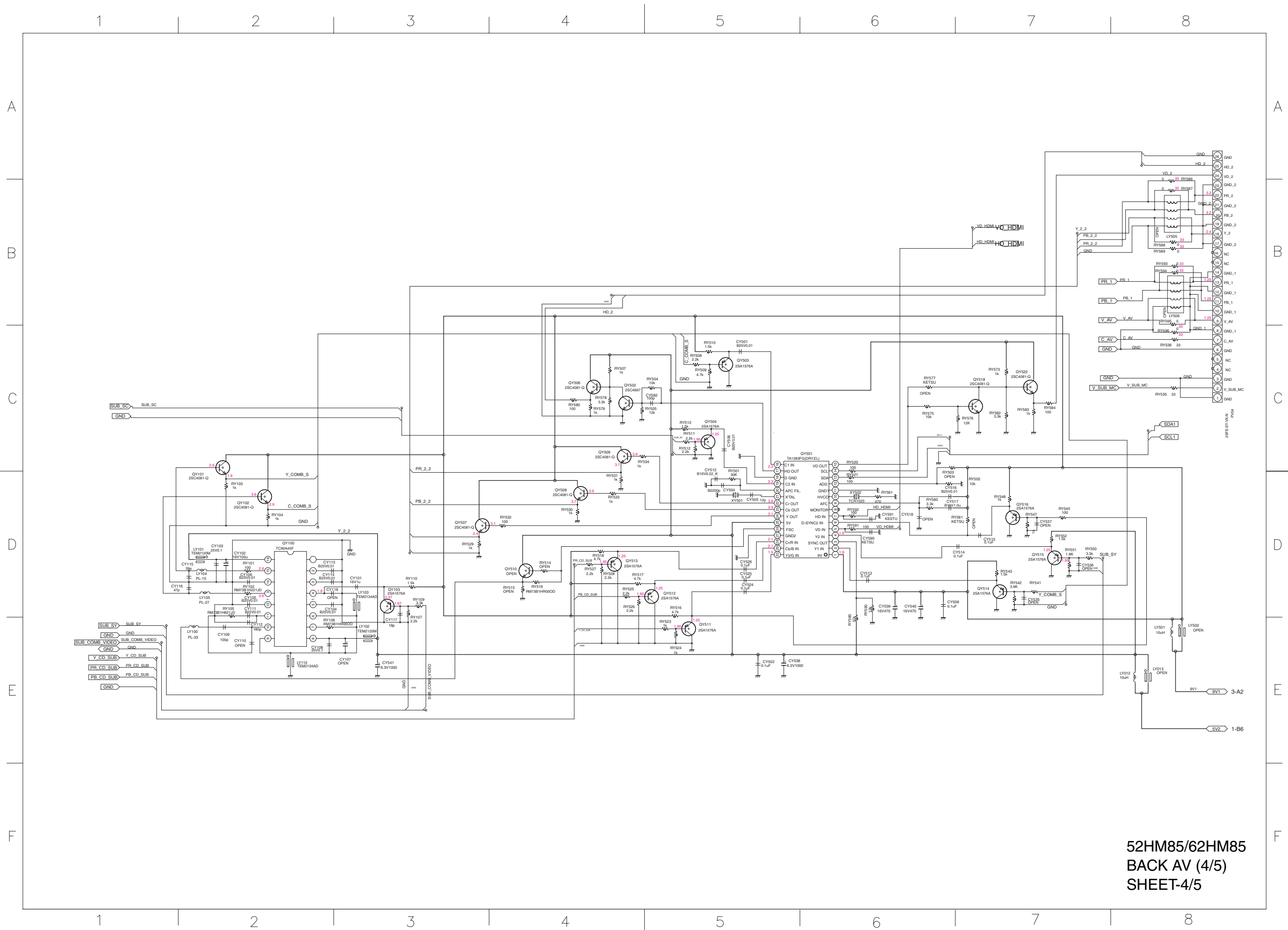

52HM85/62HM85
 BACK AV (4/5)
 SHEET-4/5

1

2

A

A

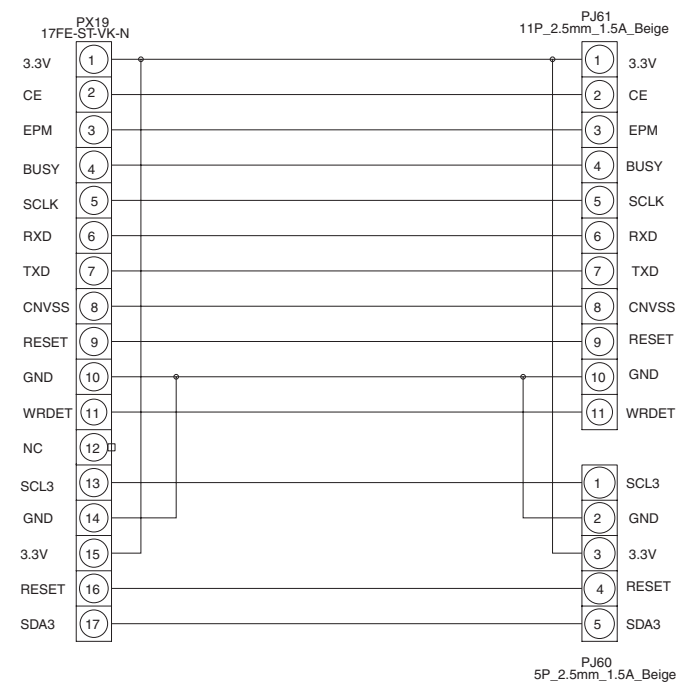
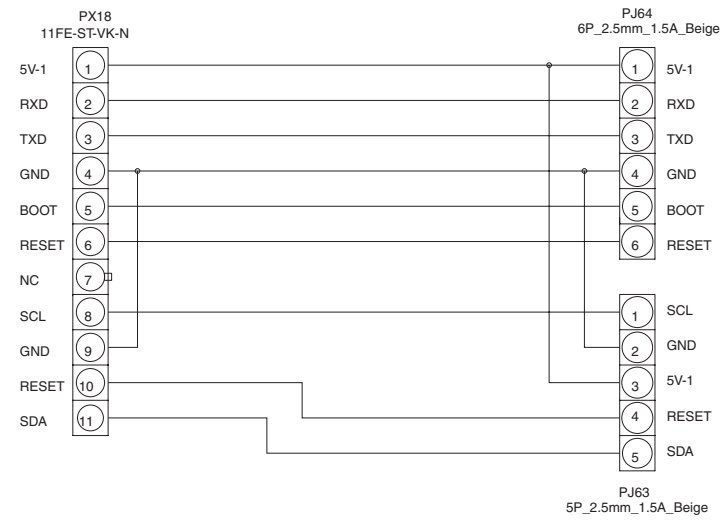

B

B

1

2

52HM85/62HM85
 BACK AV (5/5)
 SHEET-5/5

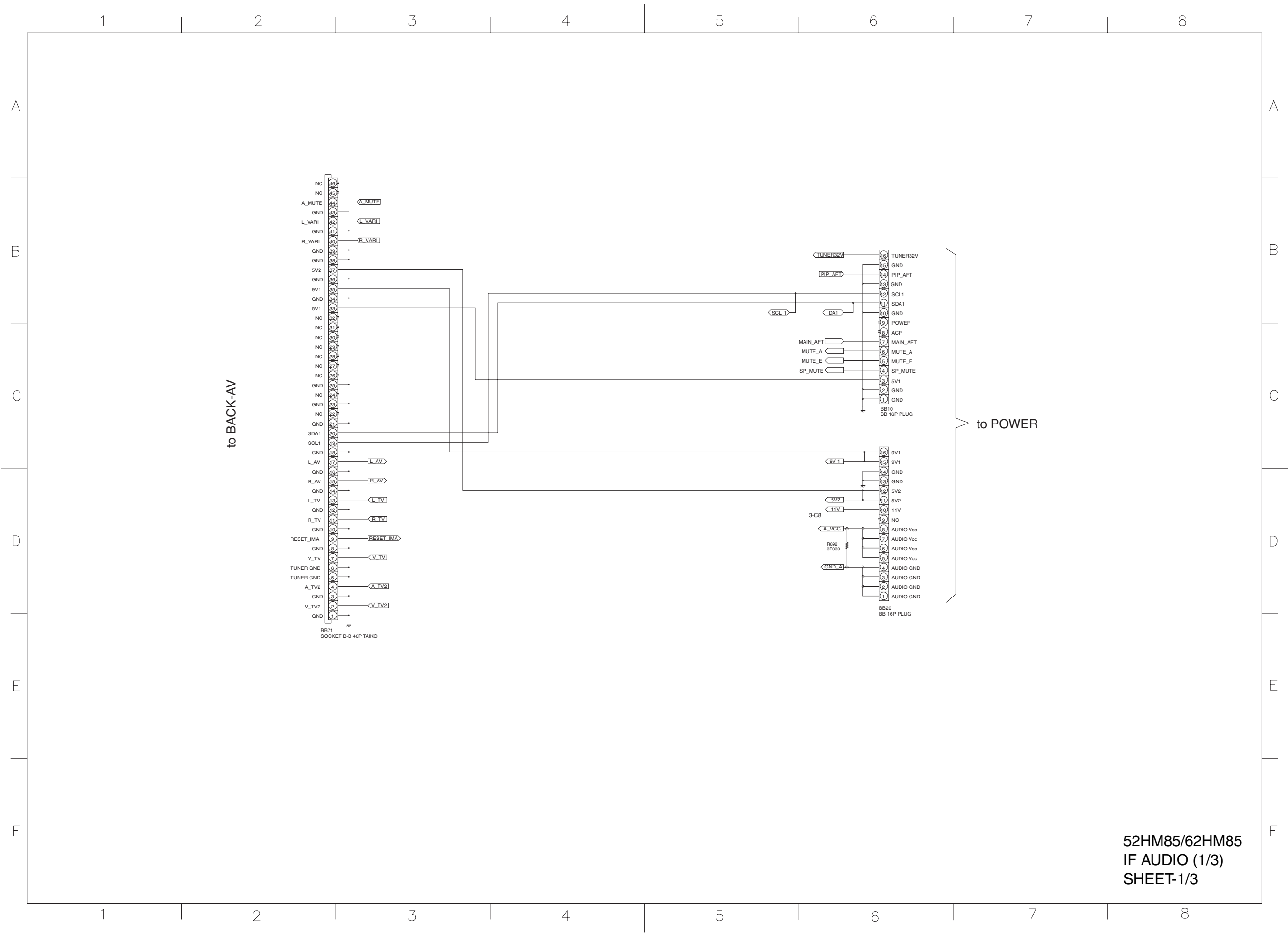

52HM85/62HM85
 IF AUDIO (1/3)
 SHEET-1/3

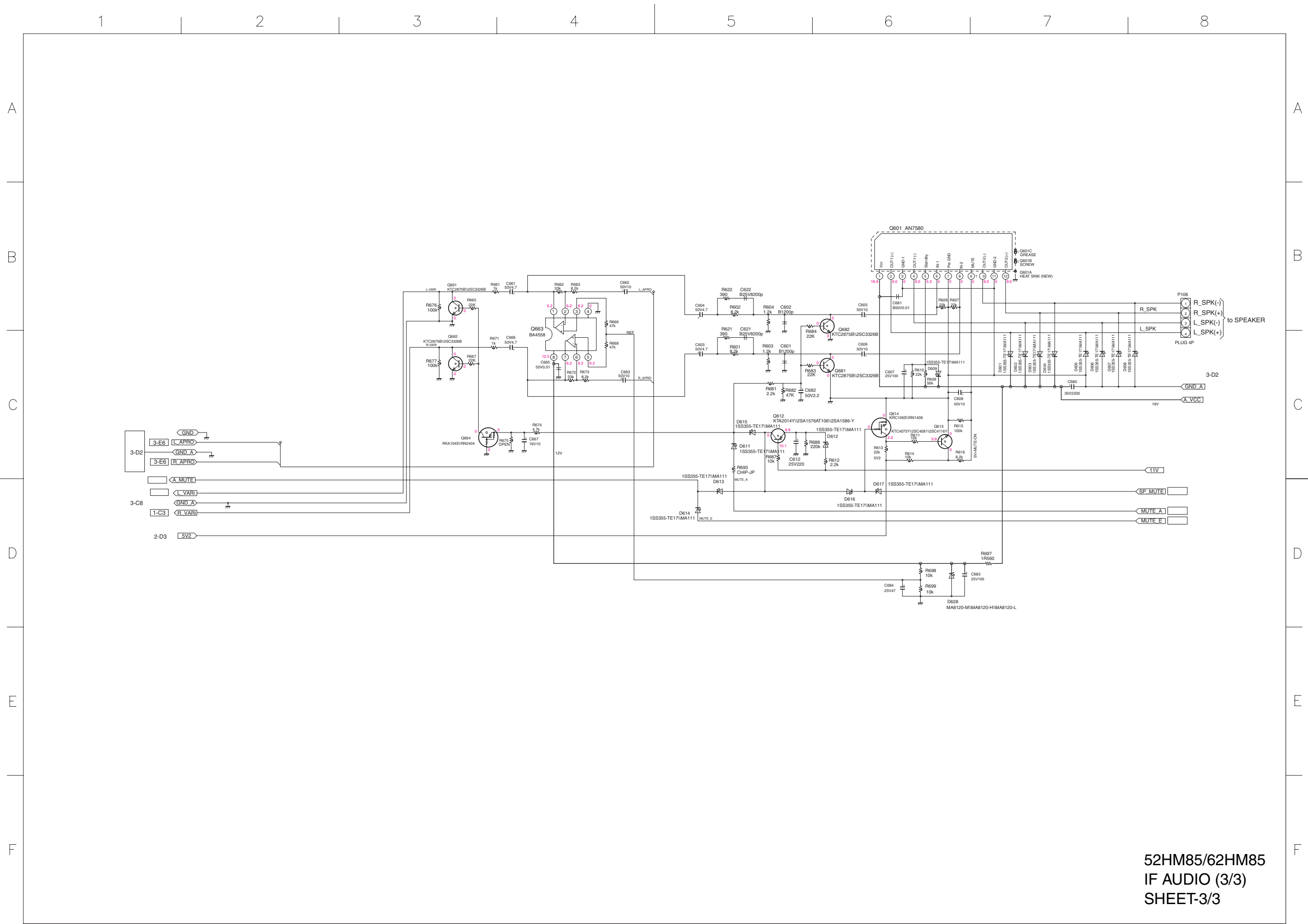

52HM85/62HM85
IF AUDIO (3/3)
SHEET-3/3

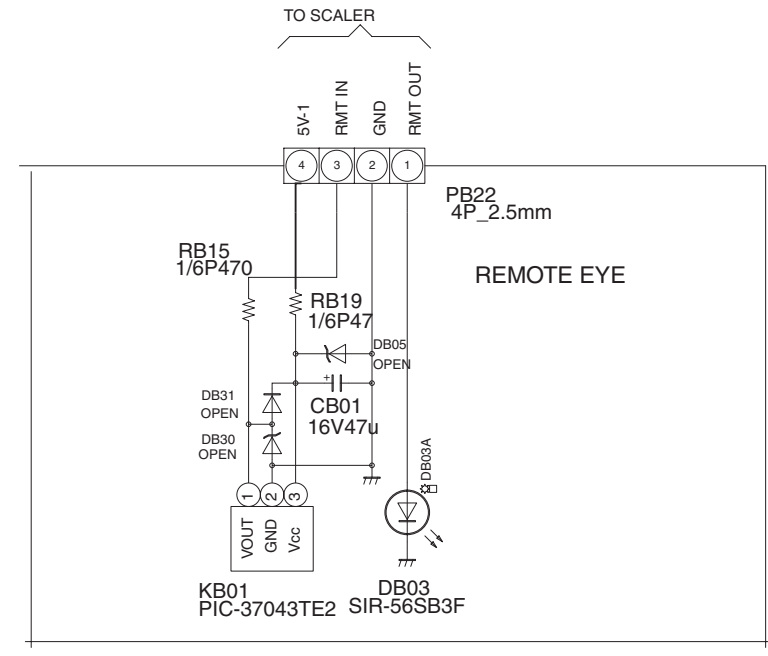
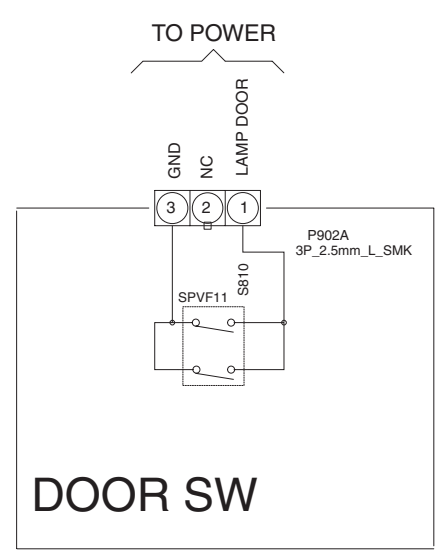
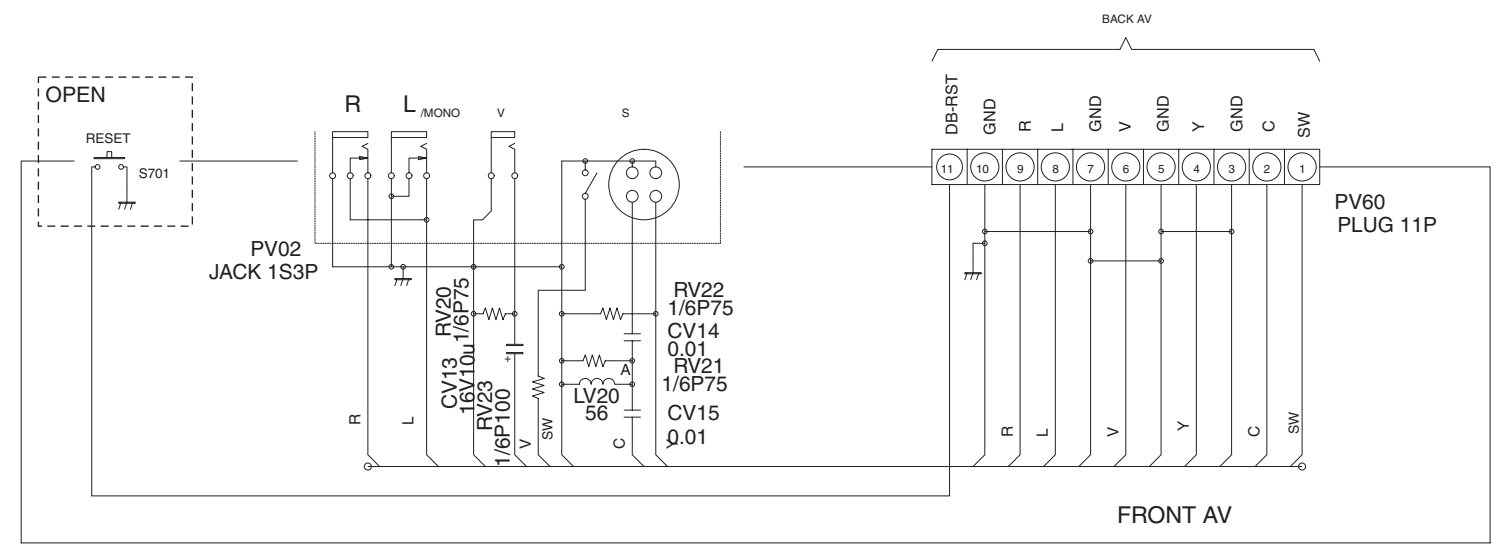

52HM85/62HM85
F-AV

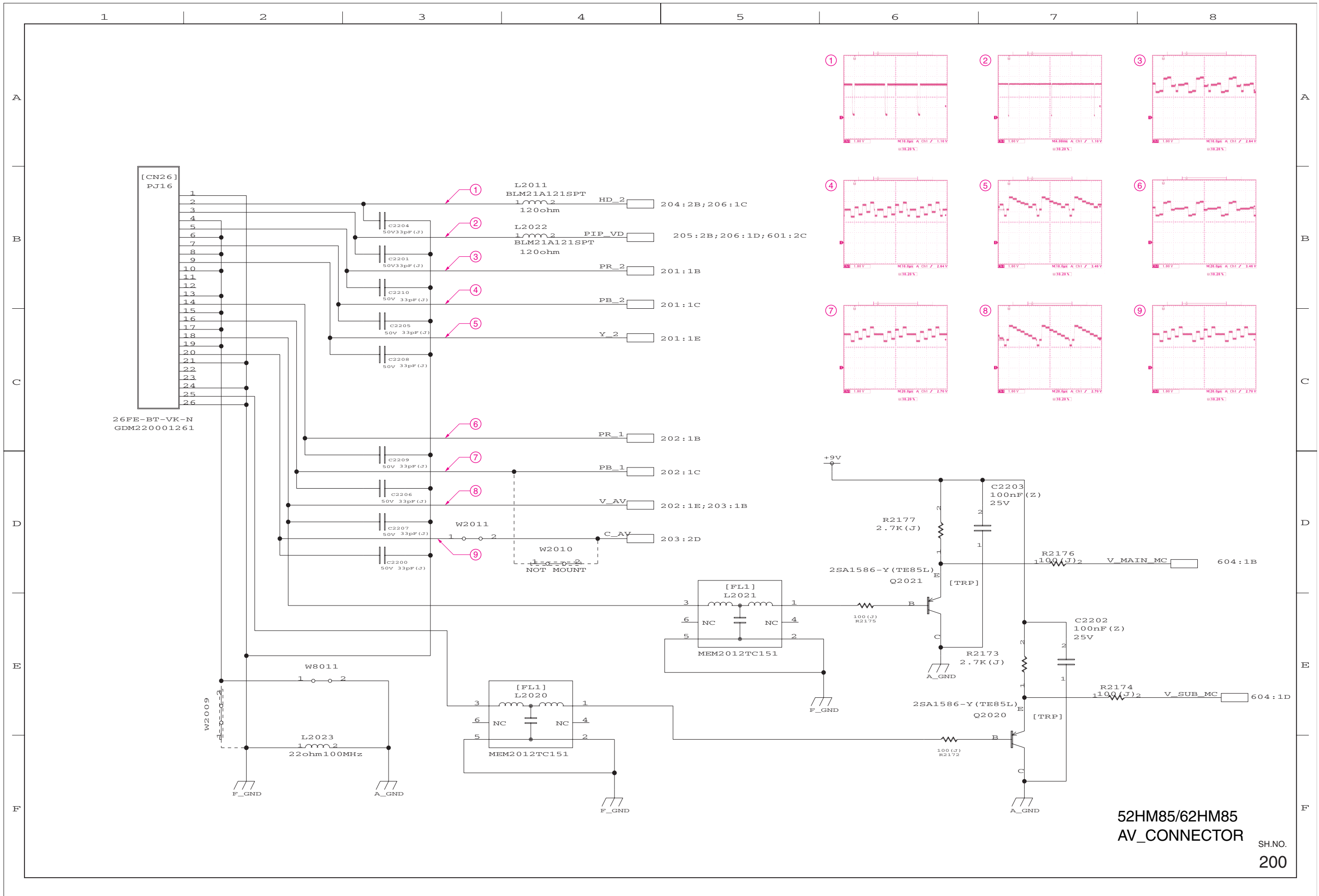

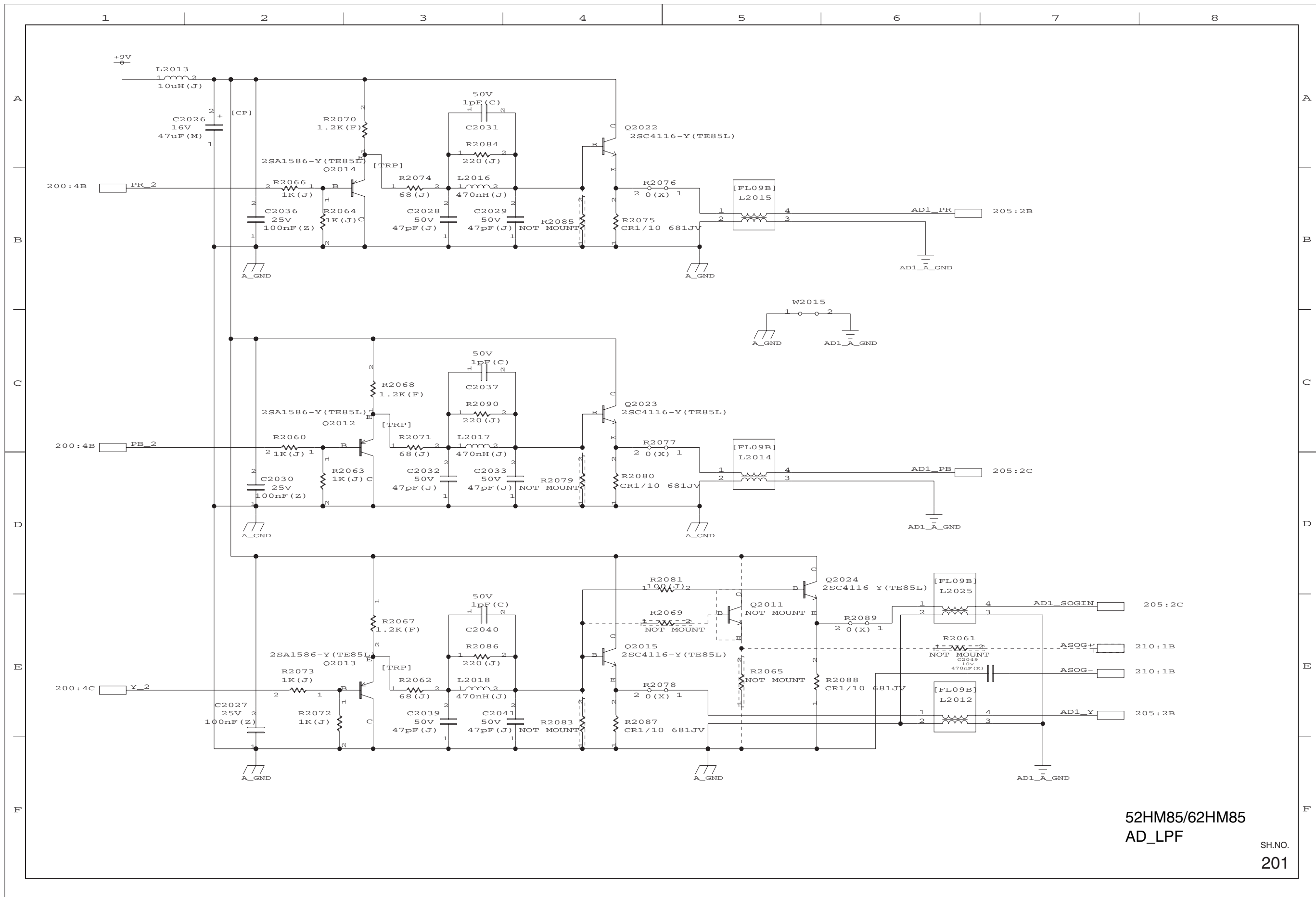

52HM85/62HM85
AD_LPF

SH.NO.
201

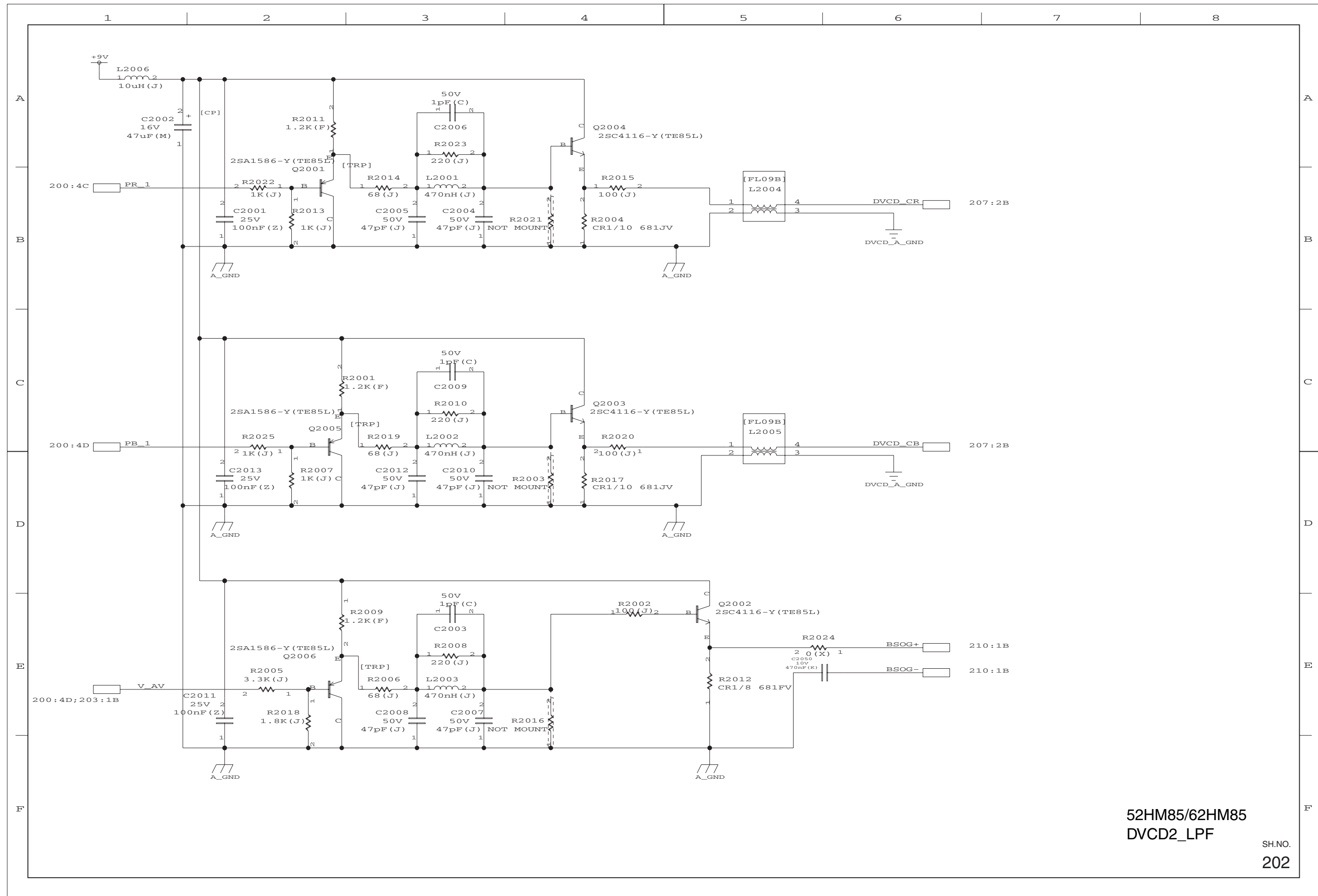

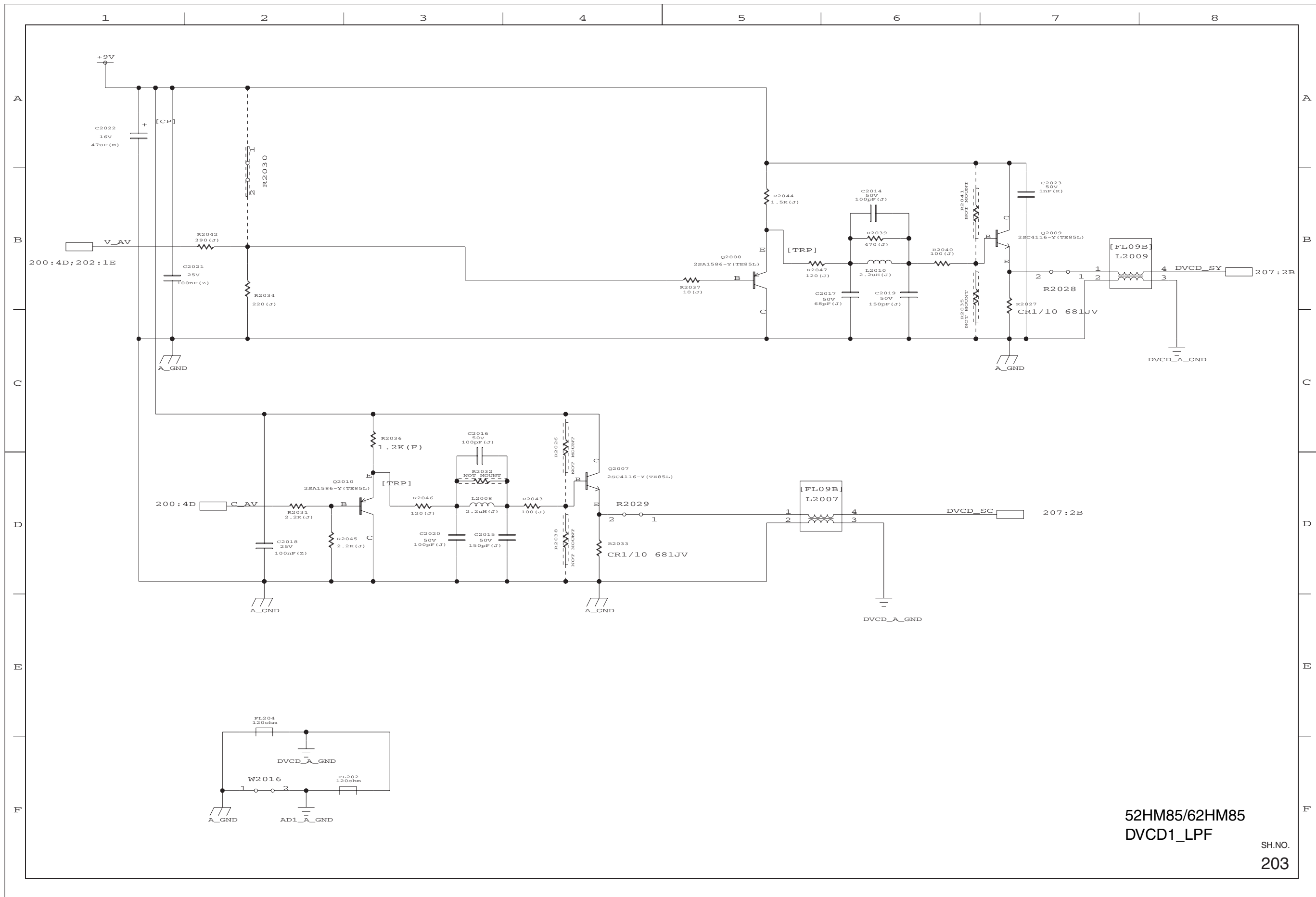

52HM85/62HM85
DVCD1_LPF

SH.NO.
203

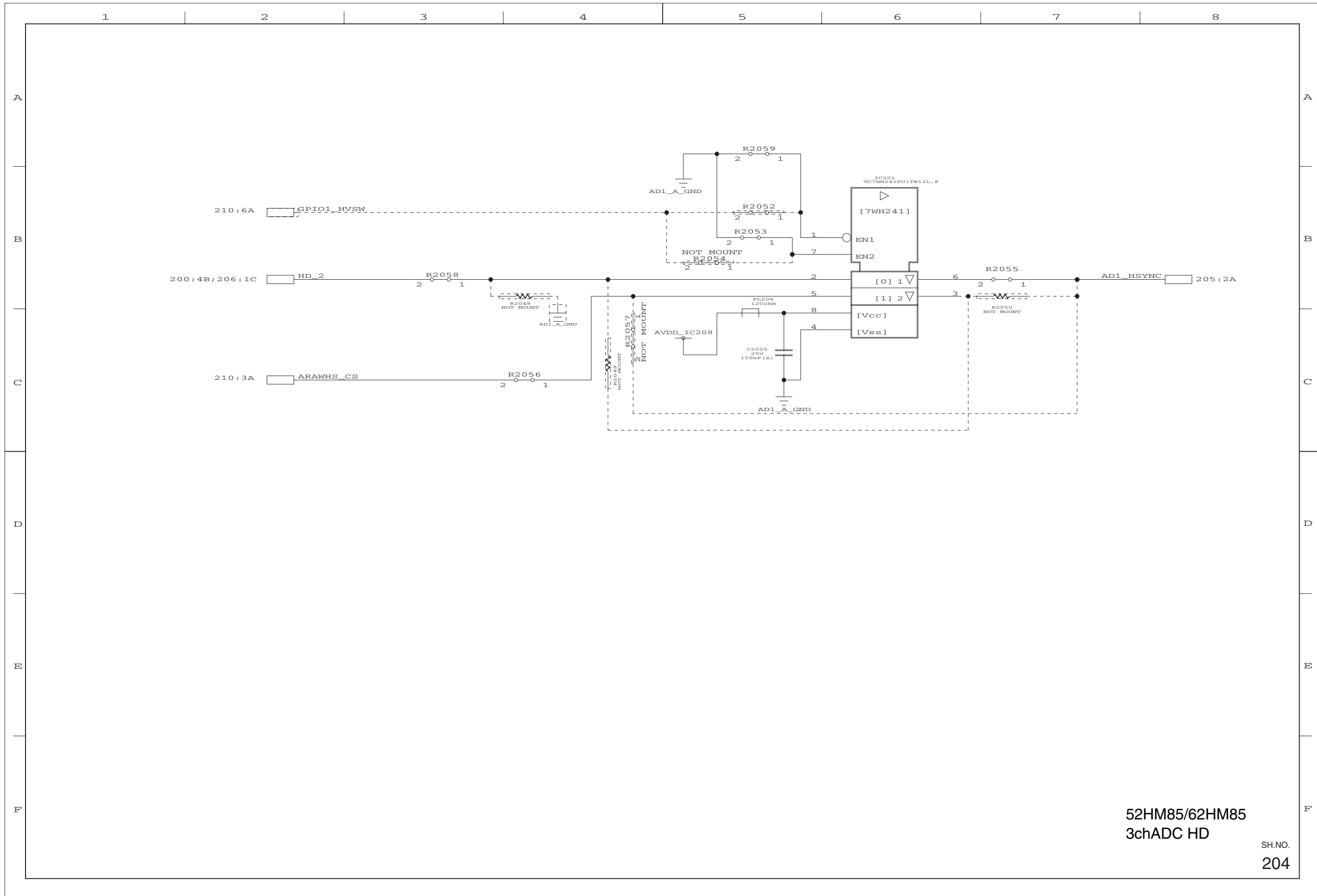

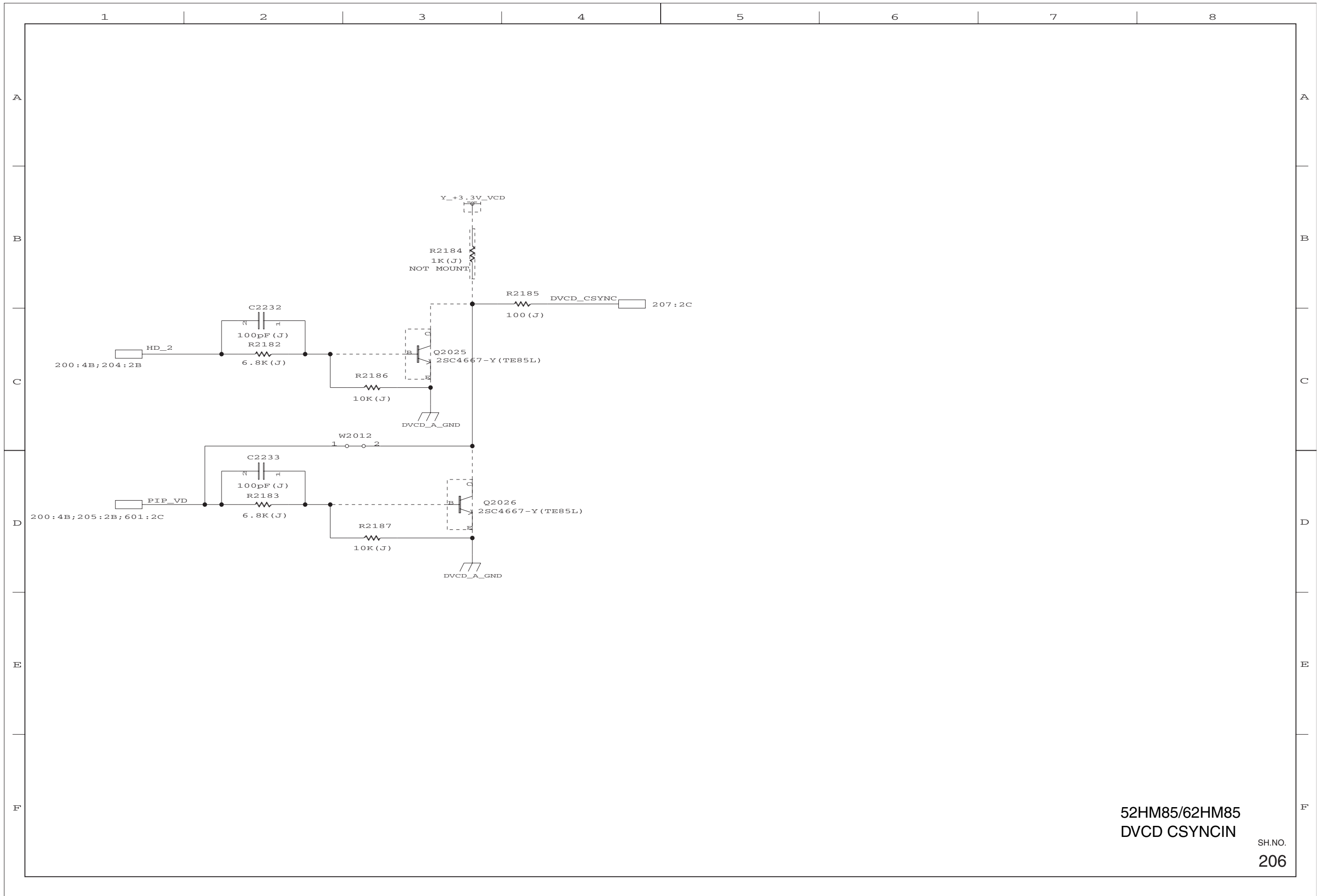

52HM85/62HM85
DVCD CSYNCIN

SH.NO.
206

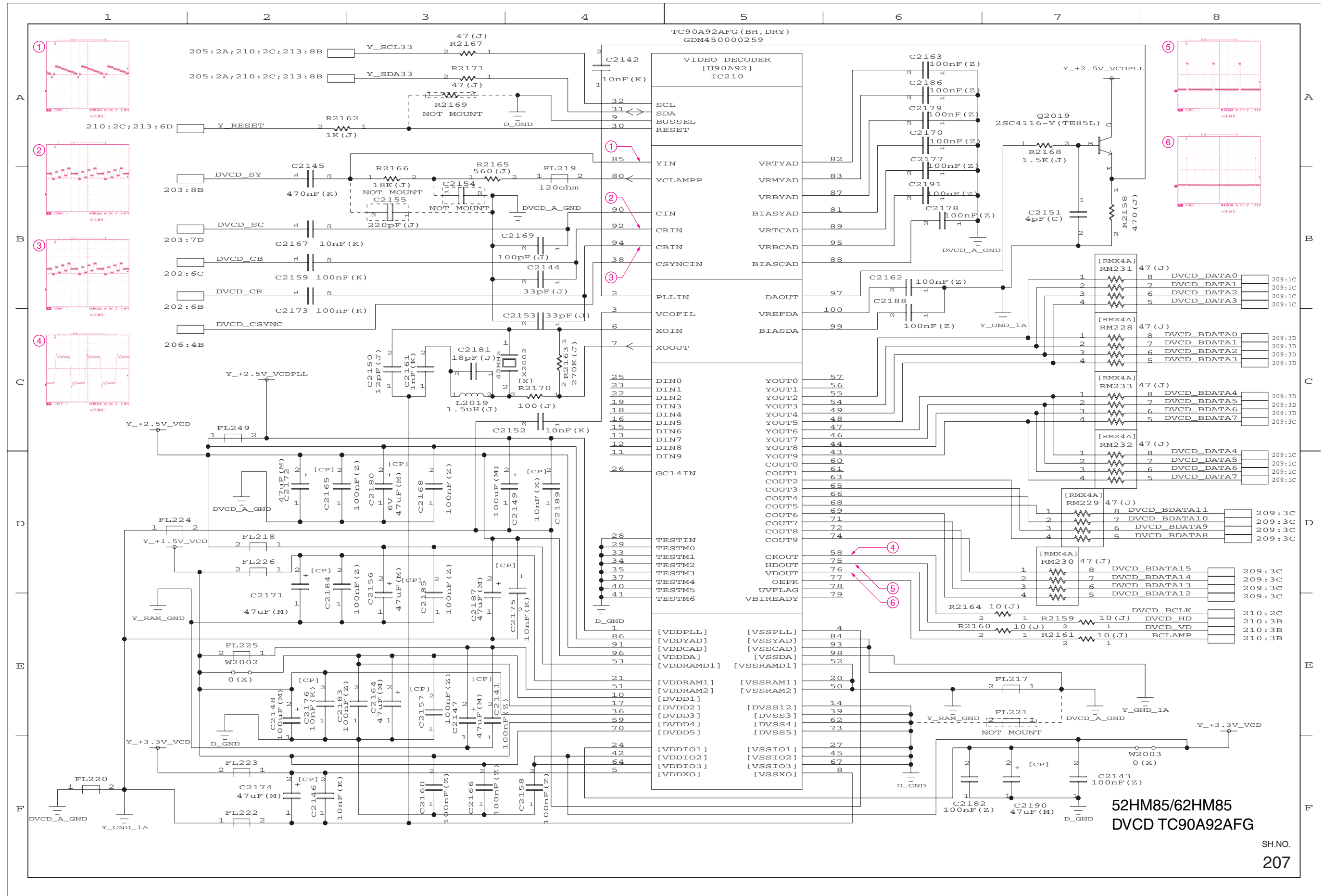

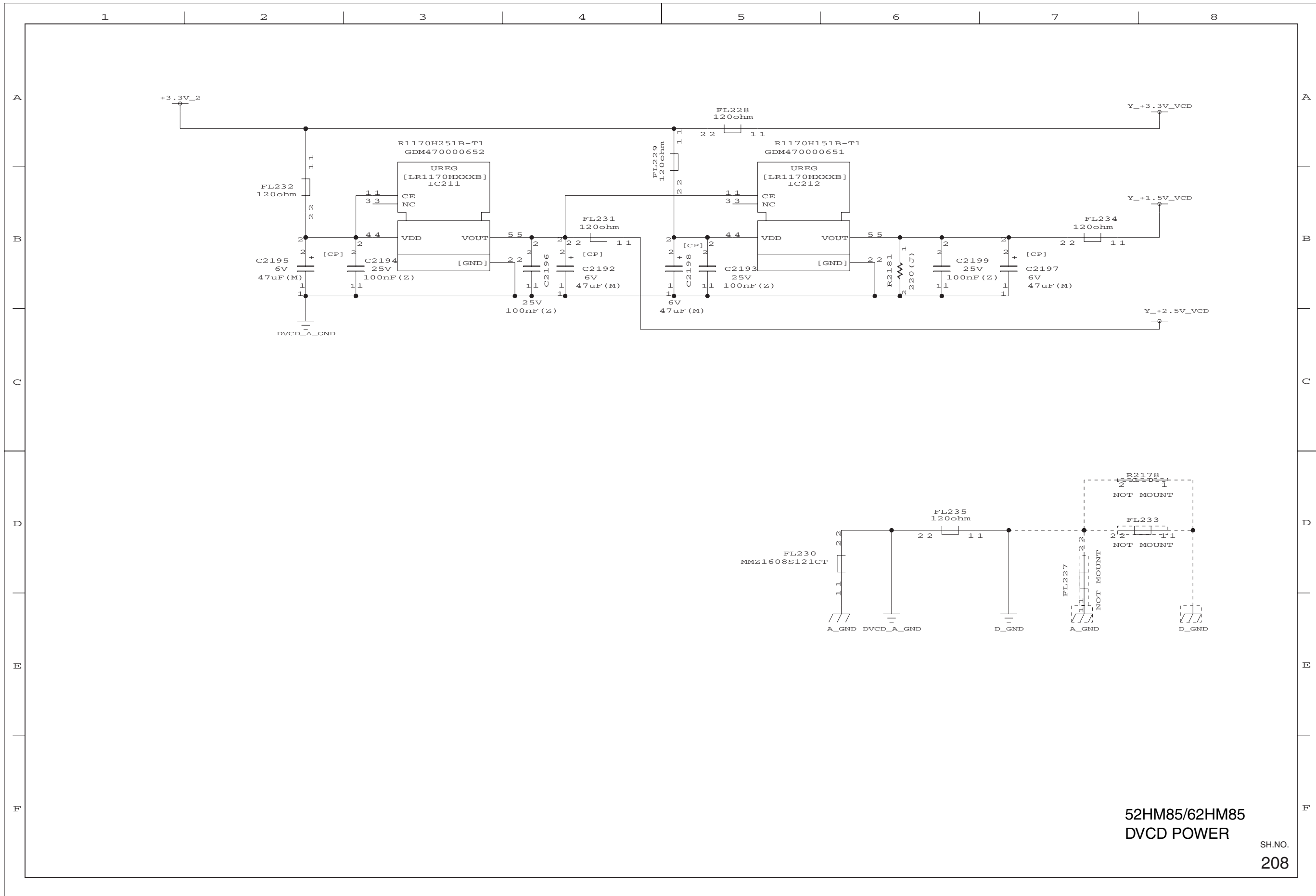

52HM85/62HM85
DVCD POWER

SH.NO.
208

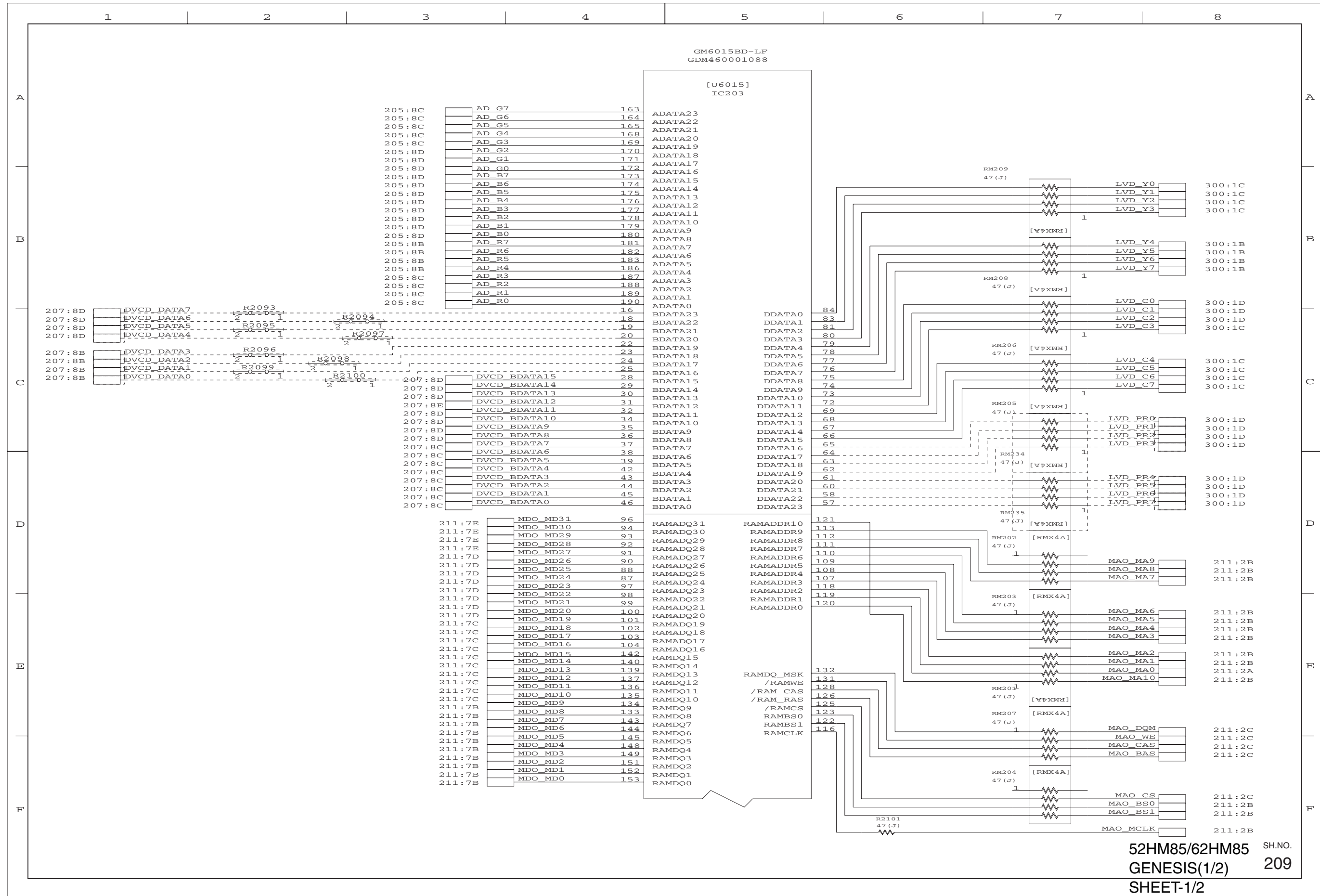

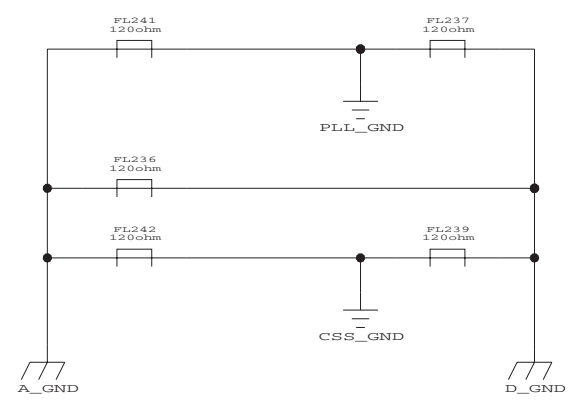
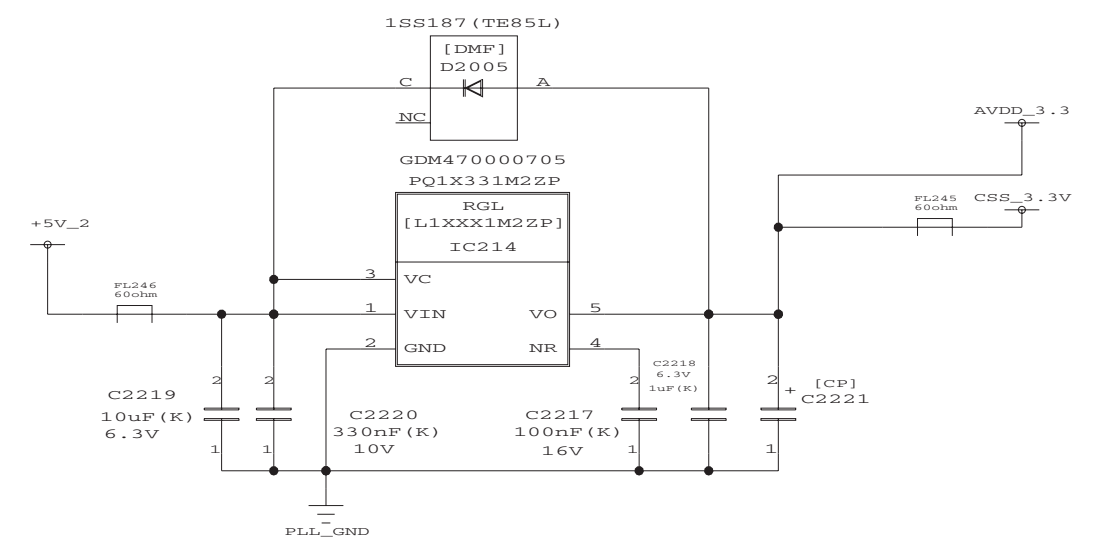
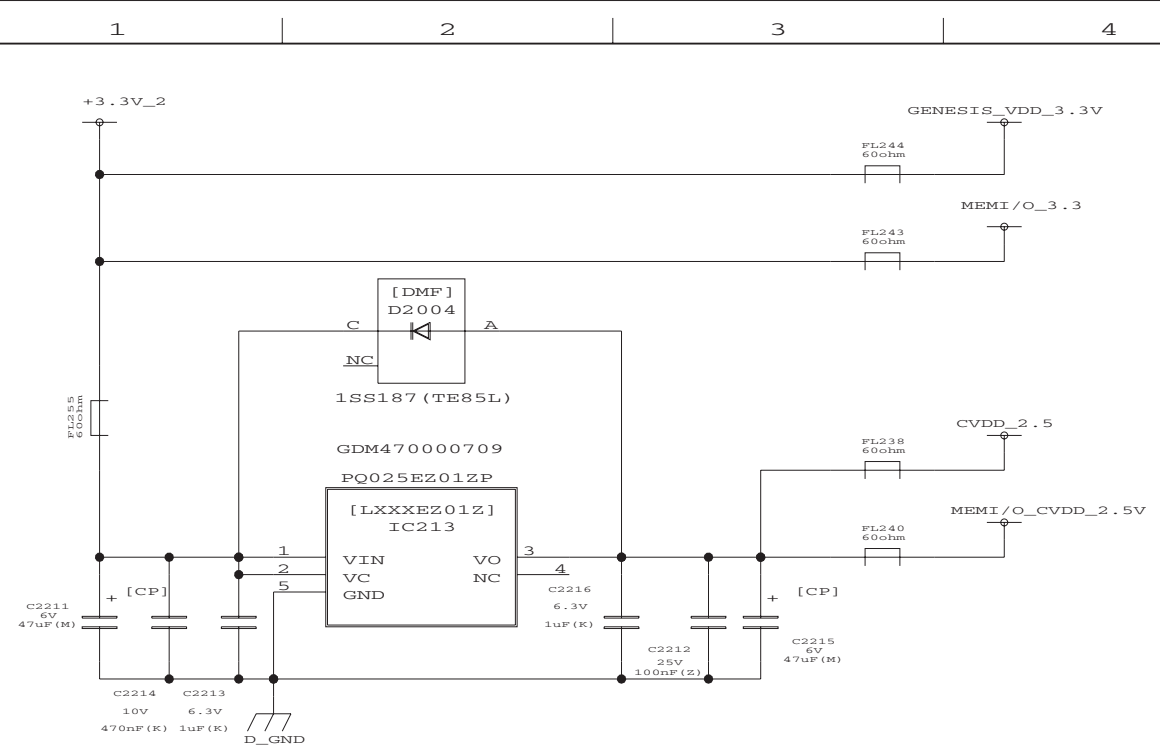

52HM85/62HM85
 GENESIS_POWER
 SH.NO.
 212

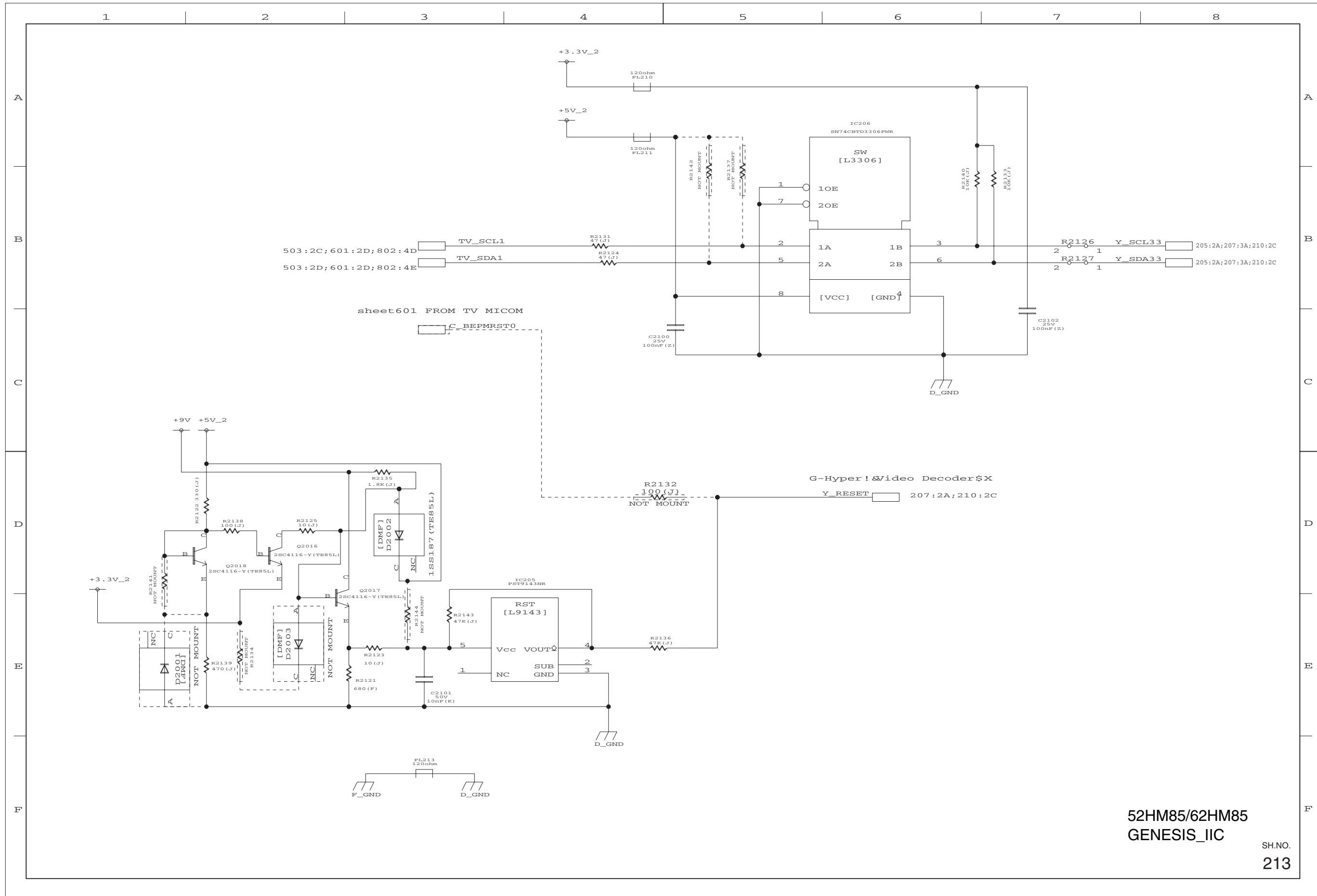

52HM85/62HM85
GENESIS_IIC

SH.NO.
213

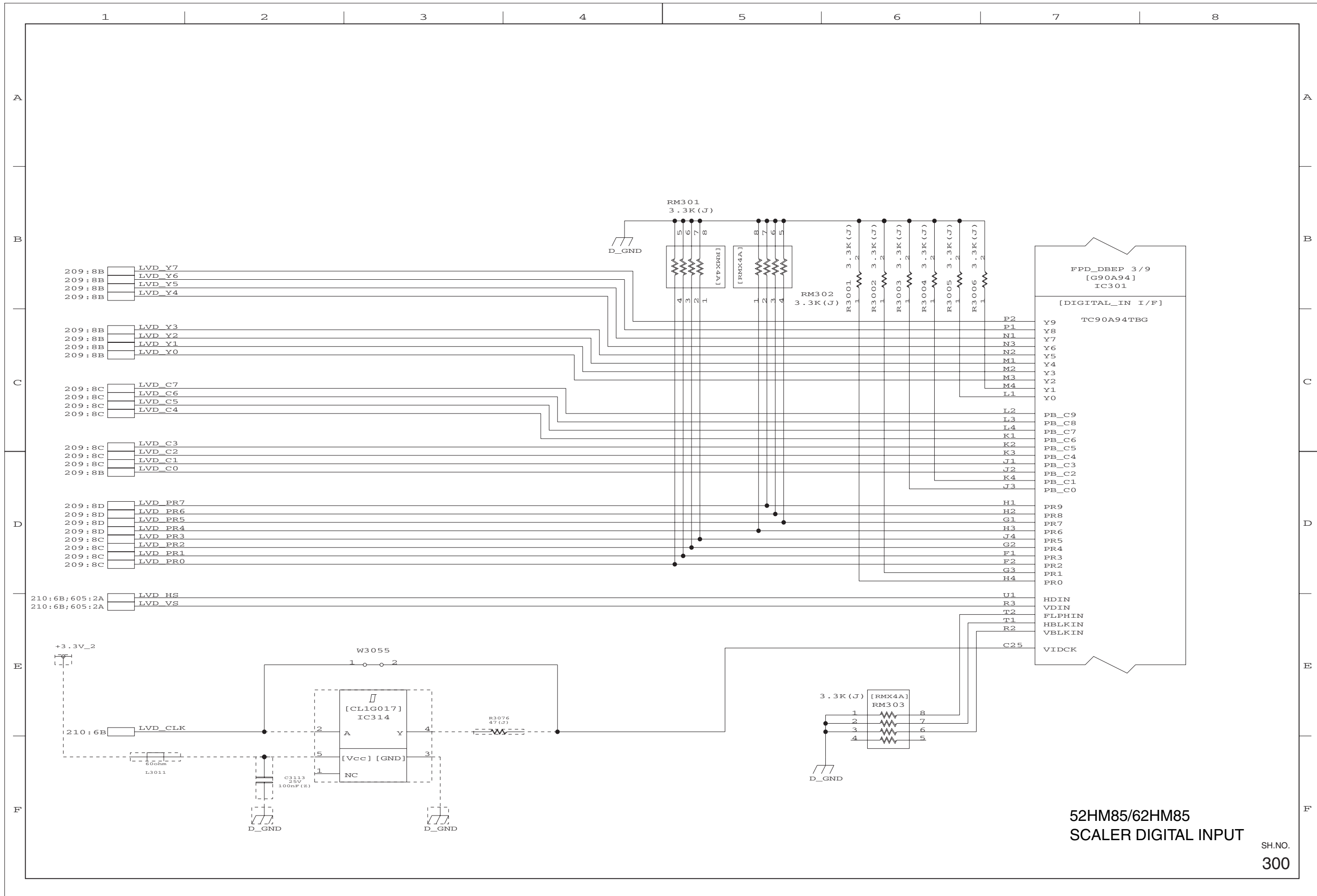

52HM85/62HM85
SCALER DIGITAL INPUT

SH.NO.
300

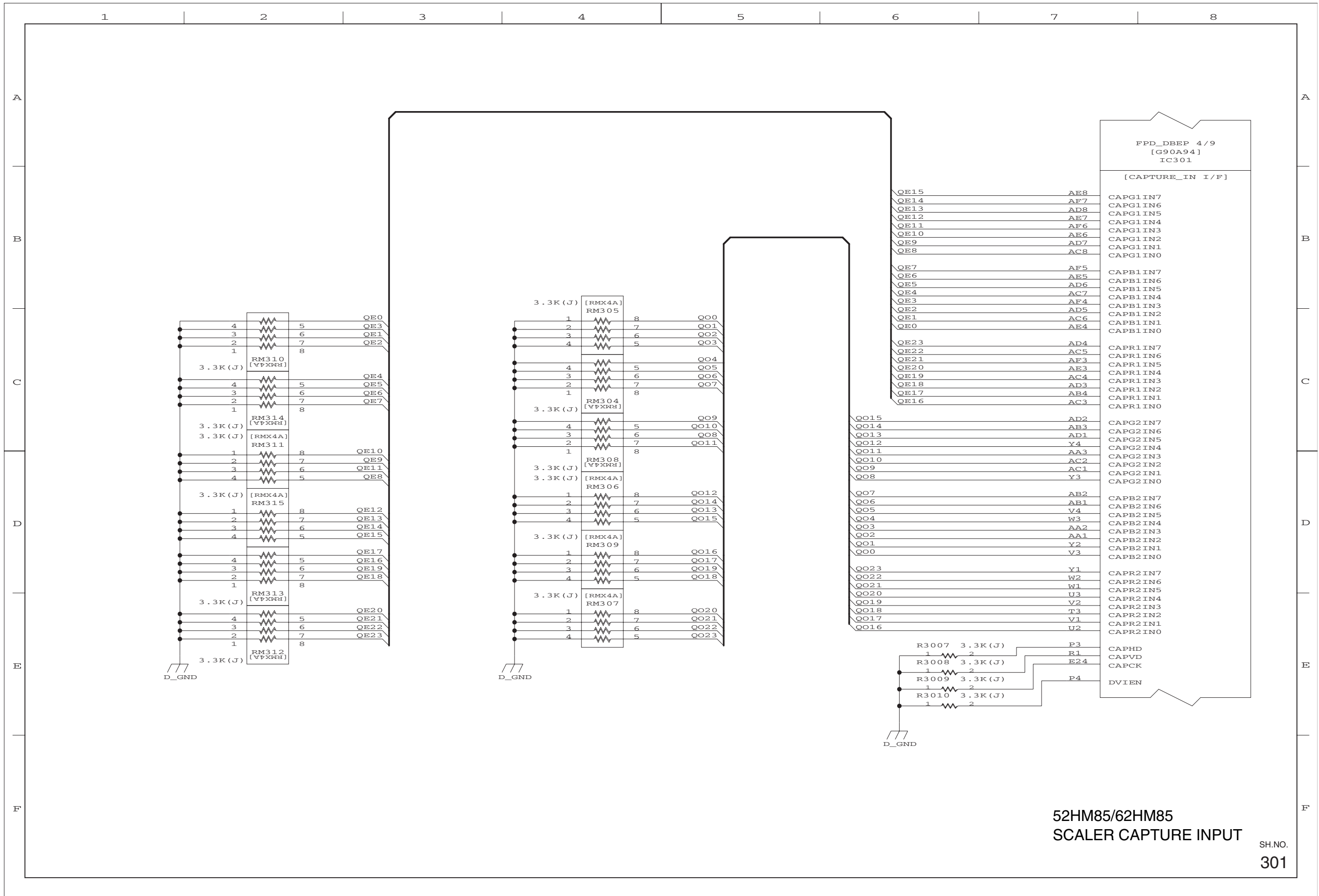

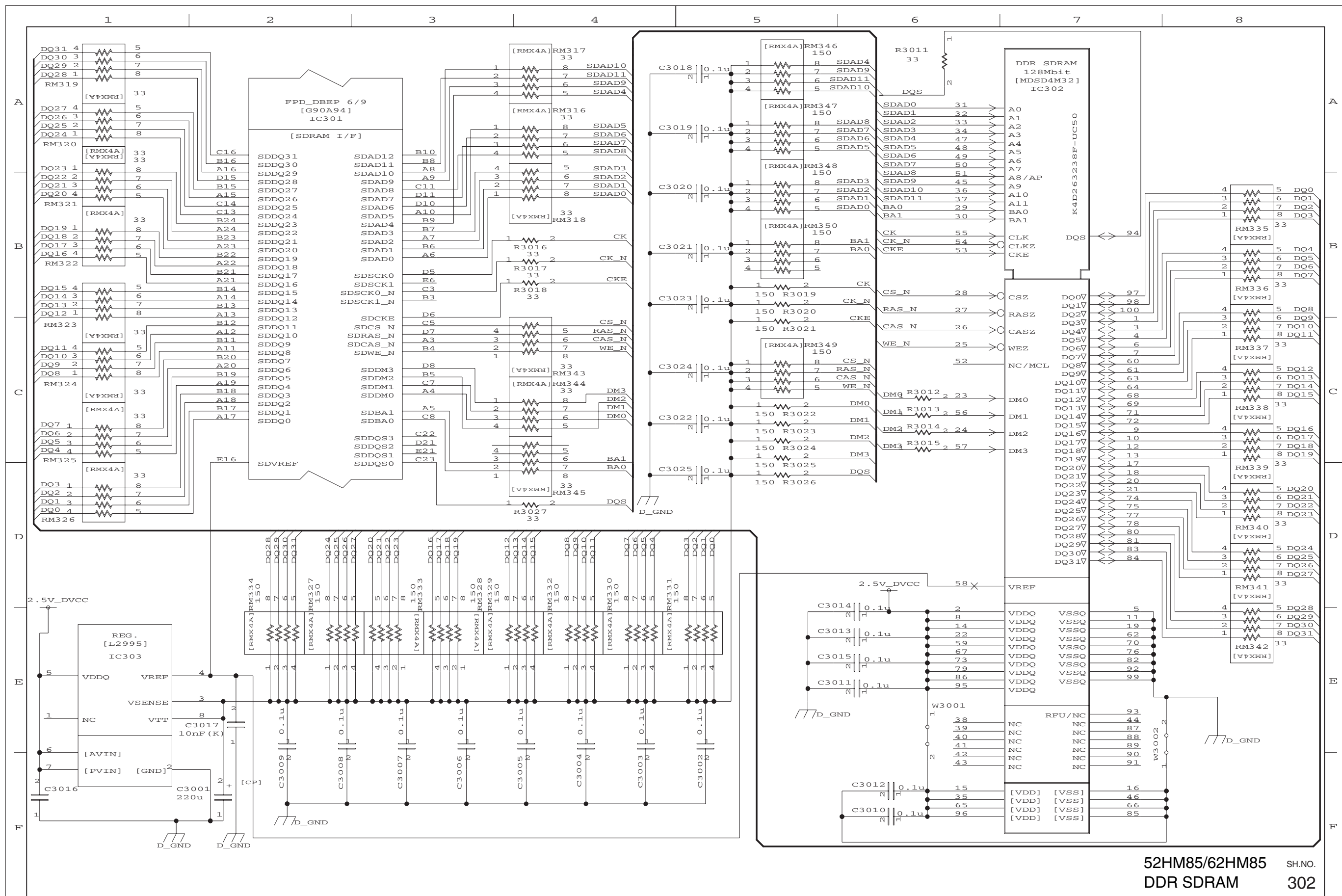

52HM85/62HM85 SH.NO.
DDR SDRAM 302

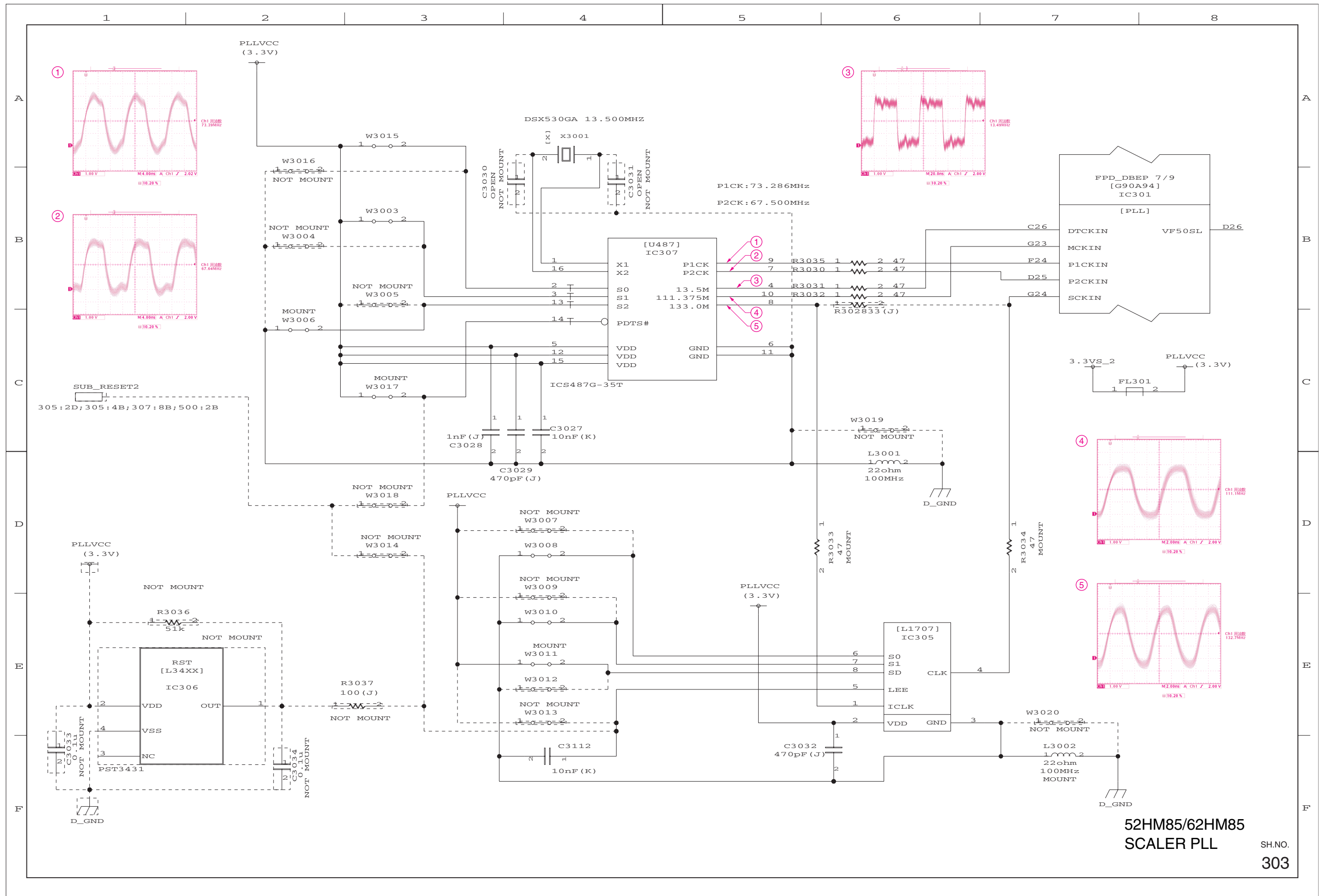

52HM85/62HM85
SCALER PLL
SH.NO.
303

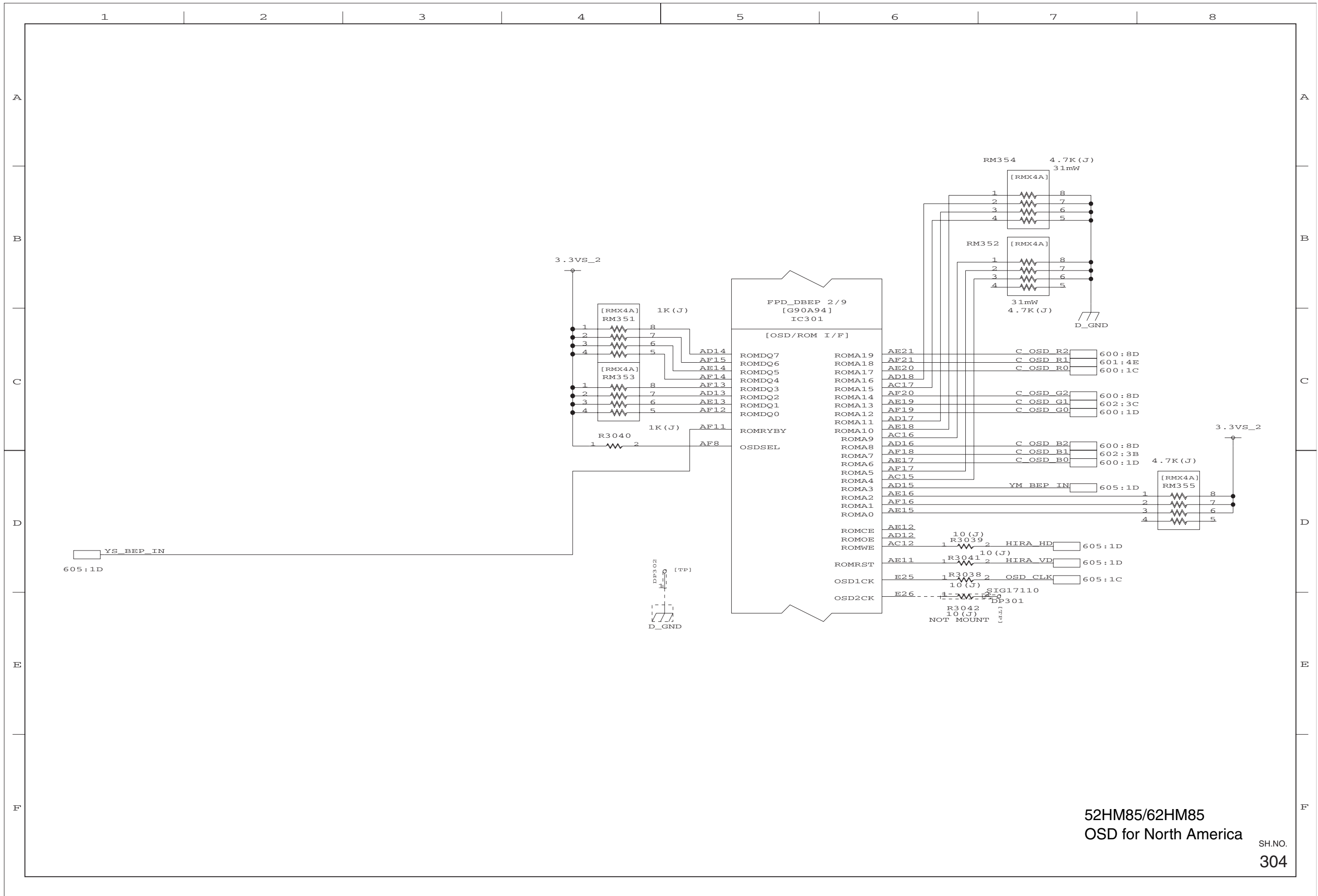

52HM85/62HM85
 OSD for North America
 SH.NO.
 304

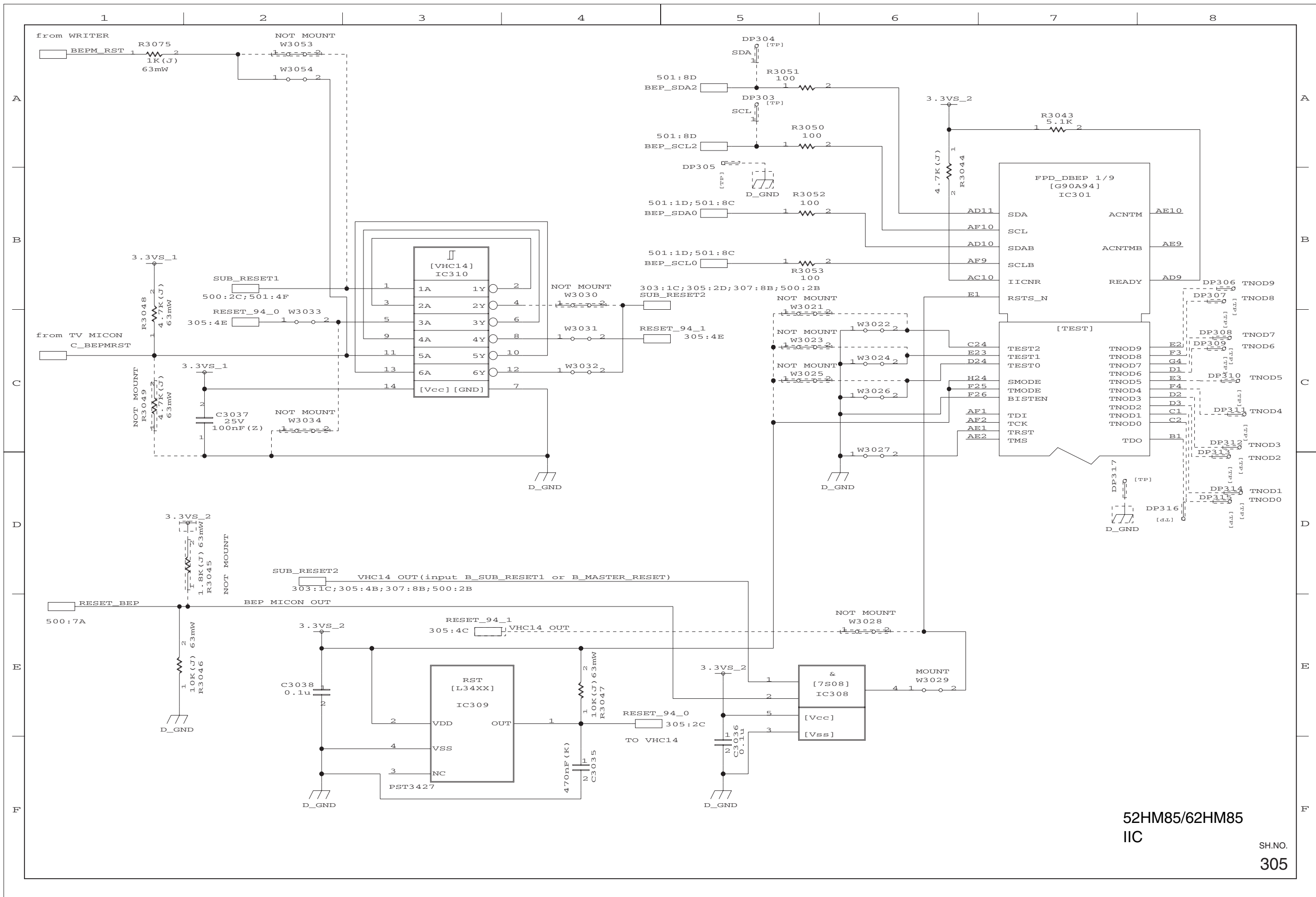

52HM85/62HM85
IIC
SH.NO.
305

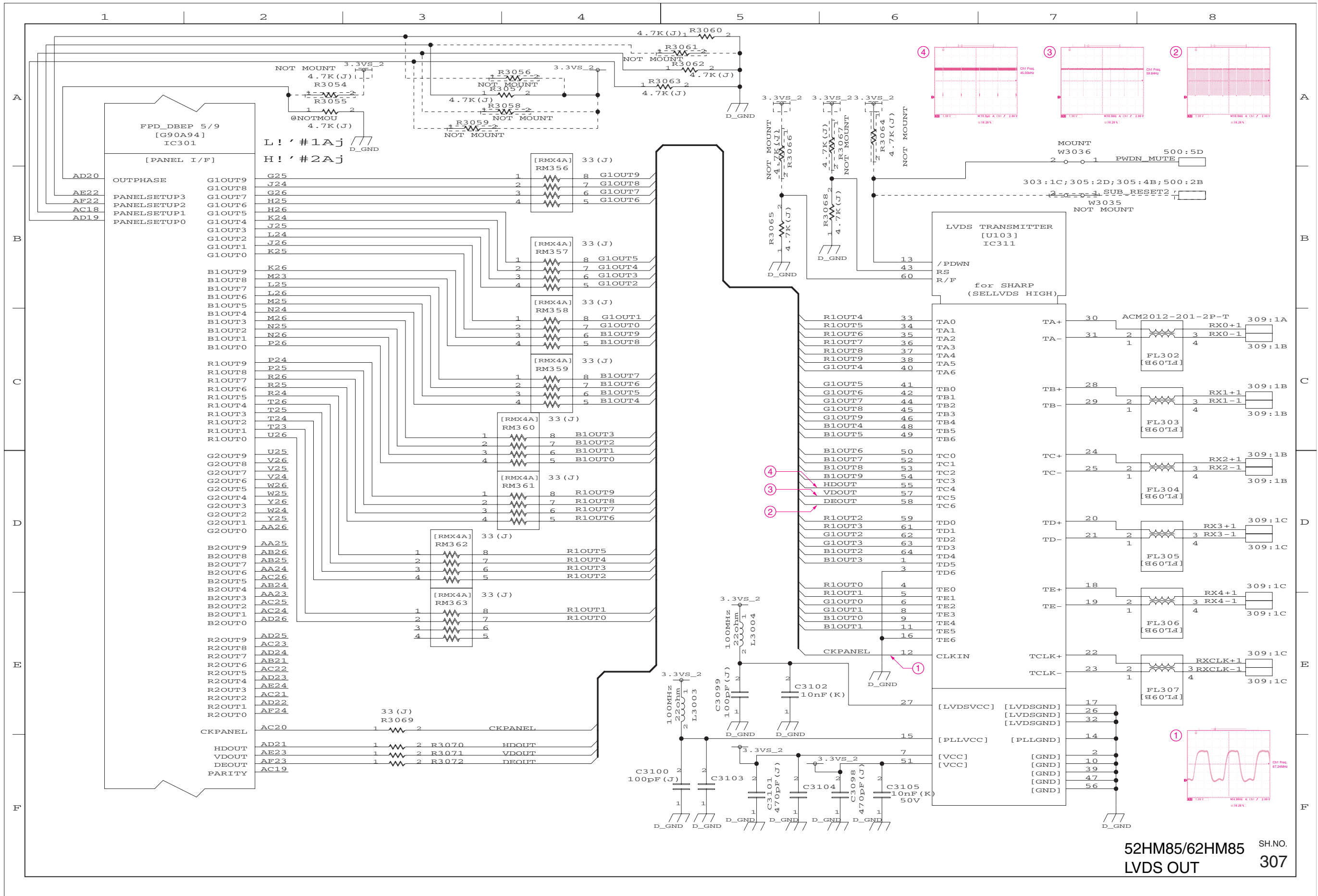

52HM85/62HM85 SH.NO. 307
LVDS OUT

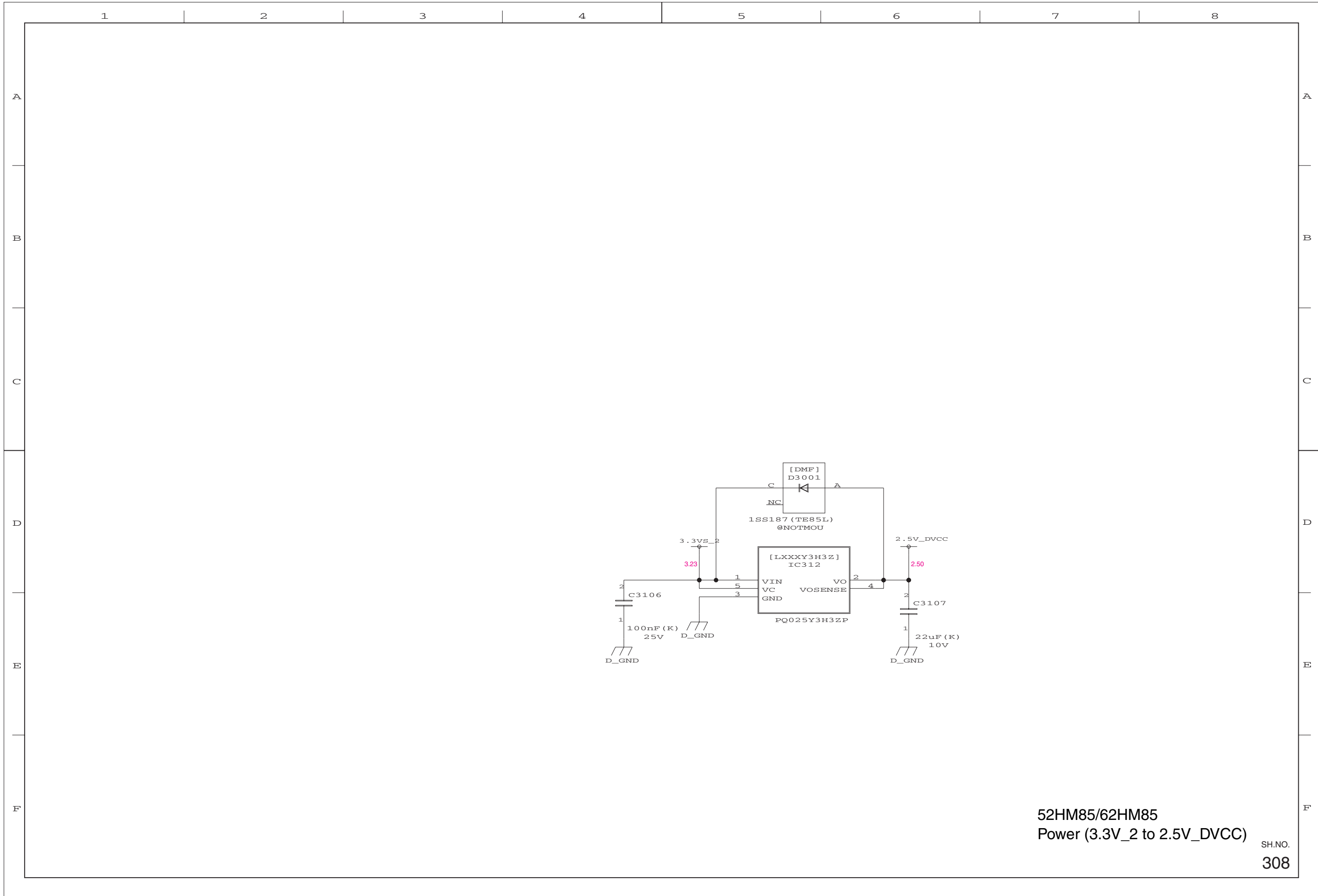

52HM85/62HM85
Power (3.3V_2 to 2.5V_DVCC)

SH.NO.
308

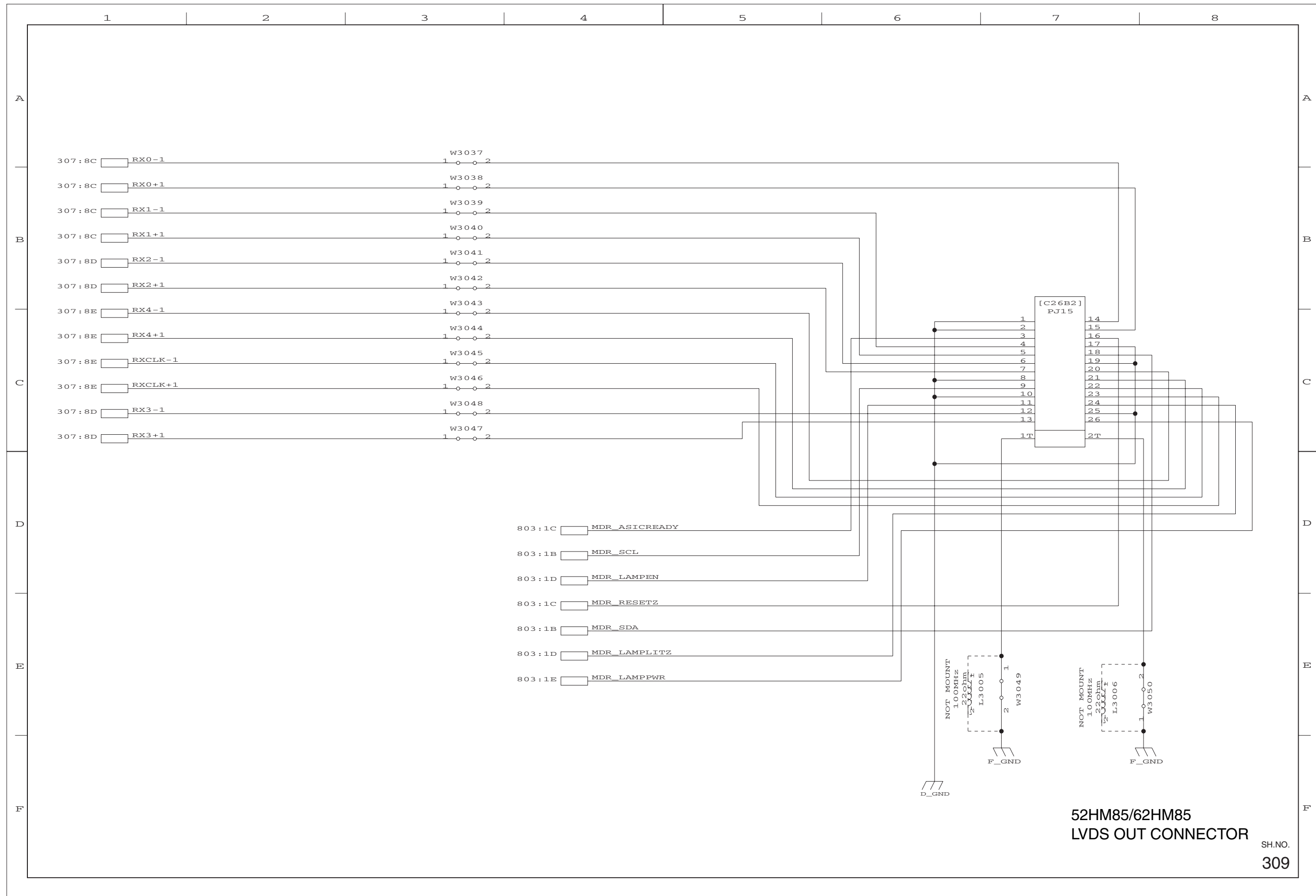

52HM85/62HM85
LVDS OUT CONNECTOR
SH.NO.
309

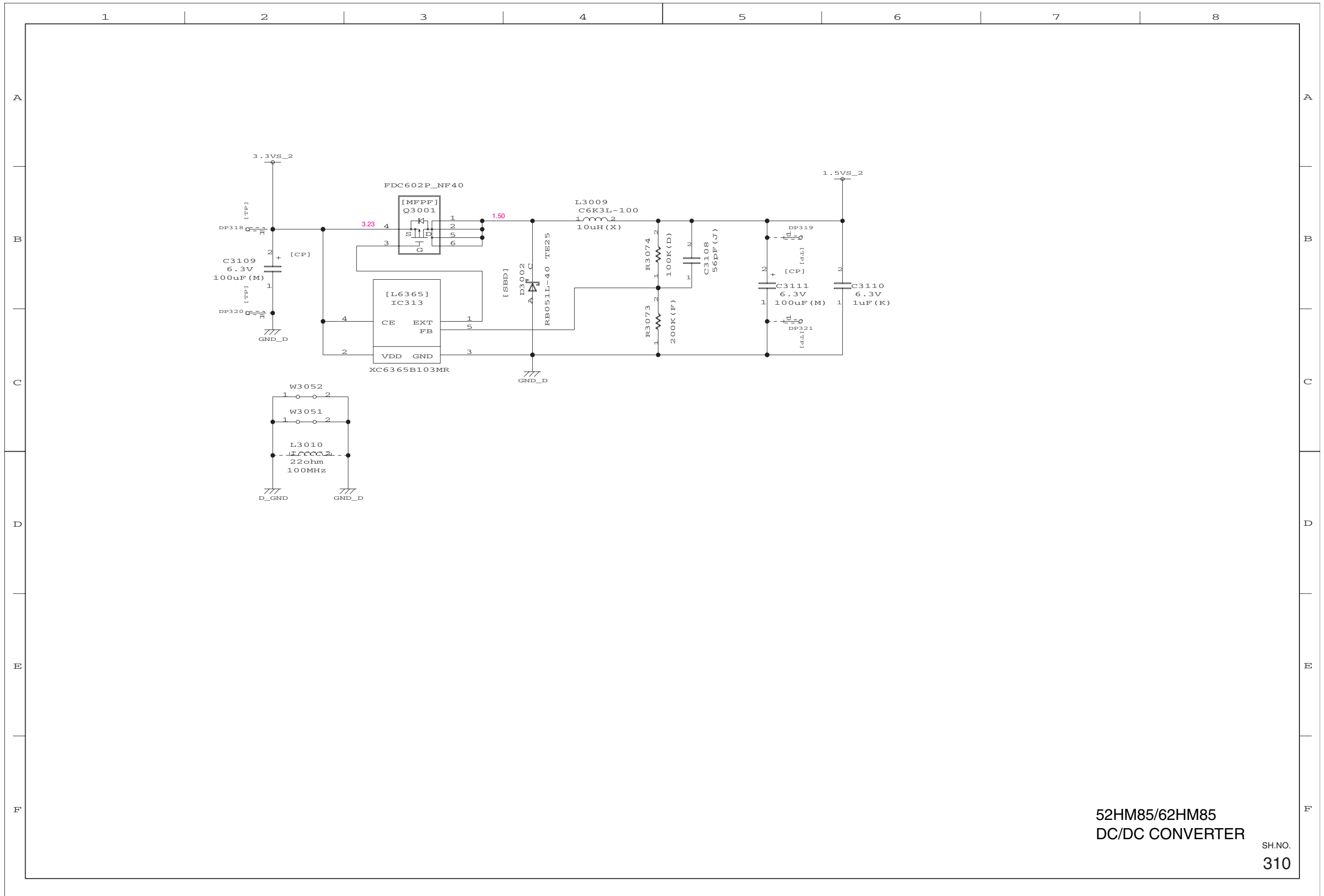

52HM85/62HM85
DC/DC CONVERTER

SH.NO.
310

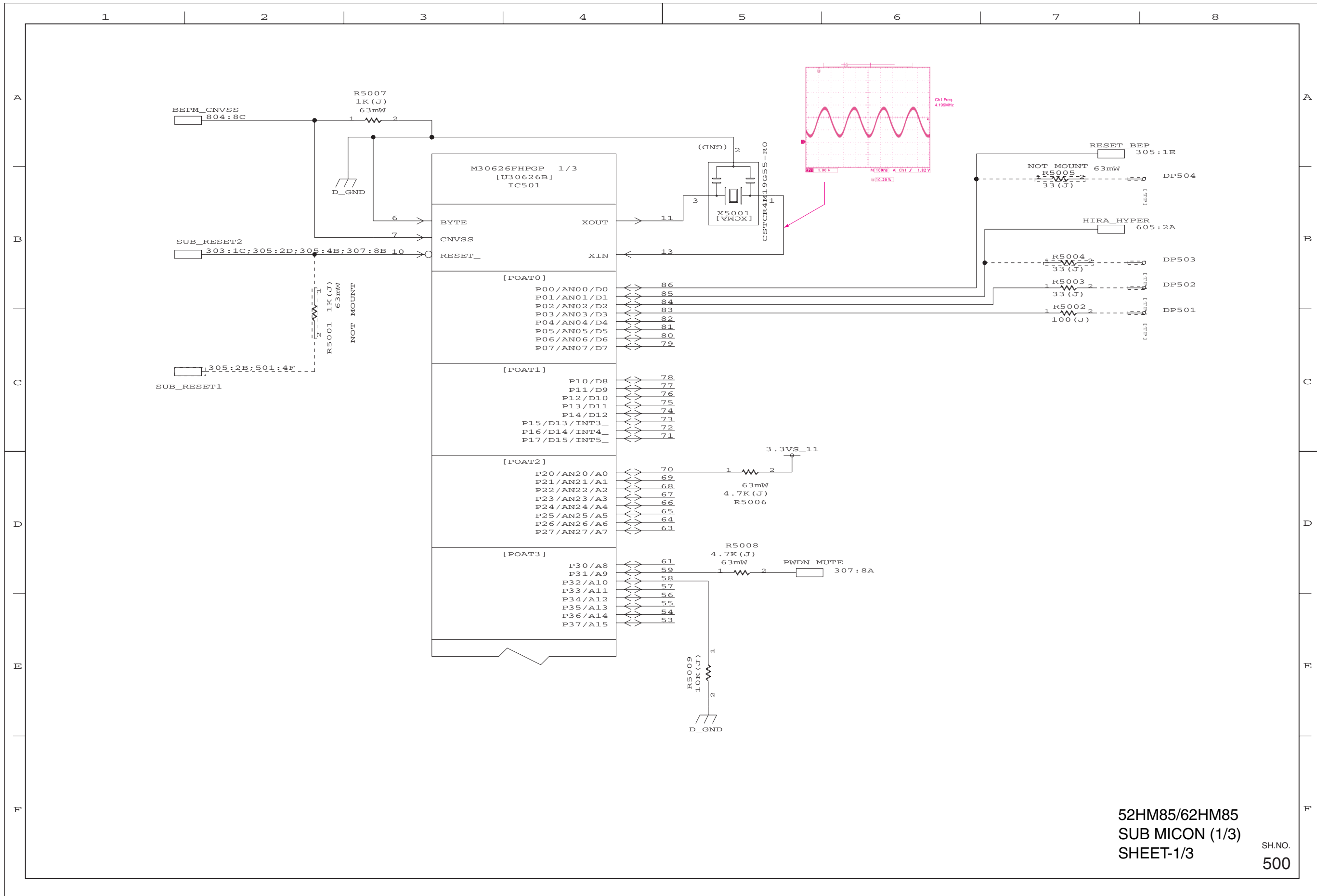

52HM85/62HM85
SUB MICON (1/3)
SHEET-1/3

SH.NO.
500

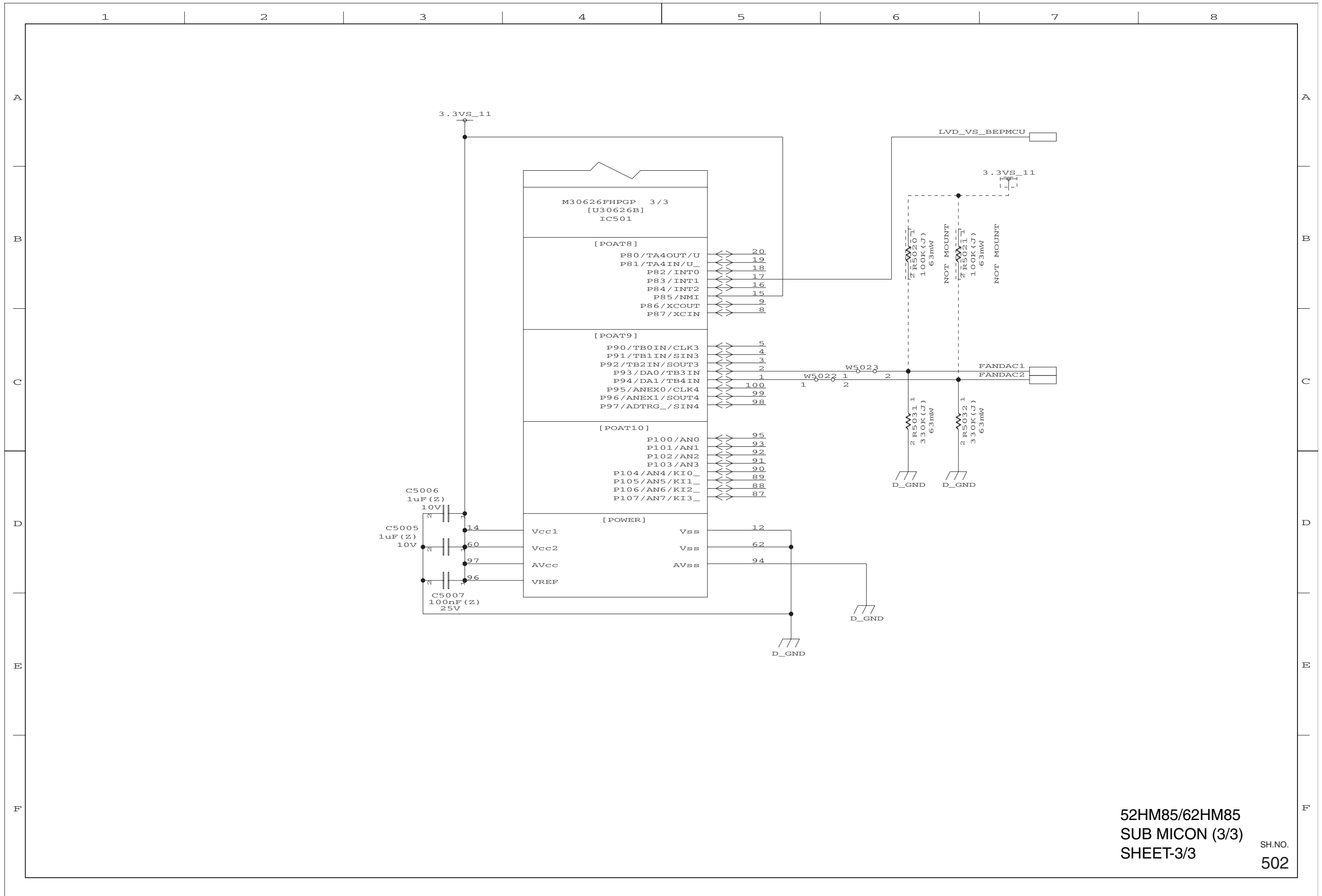

52HM85/62HM85
 SUB MICON (3/3)
 SHEET-3/3
 SH.NO.
 502

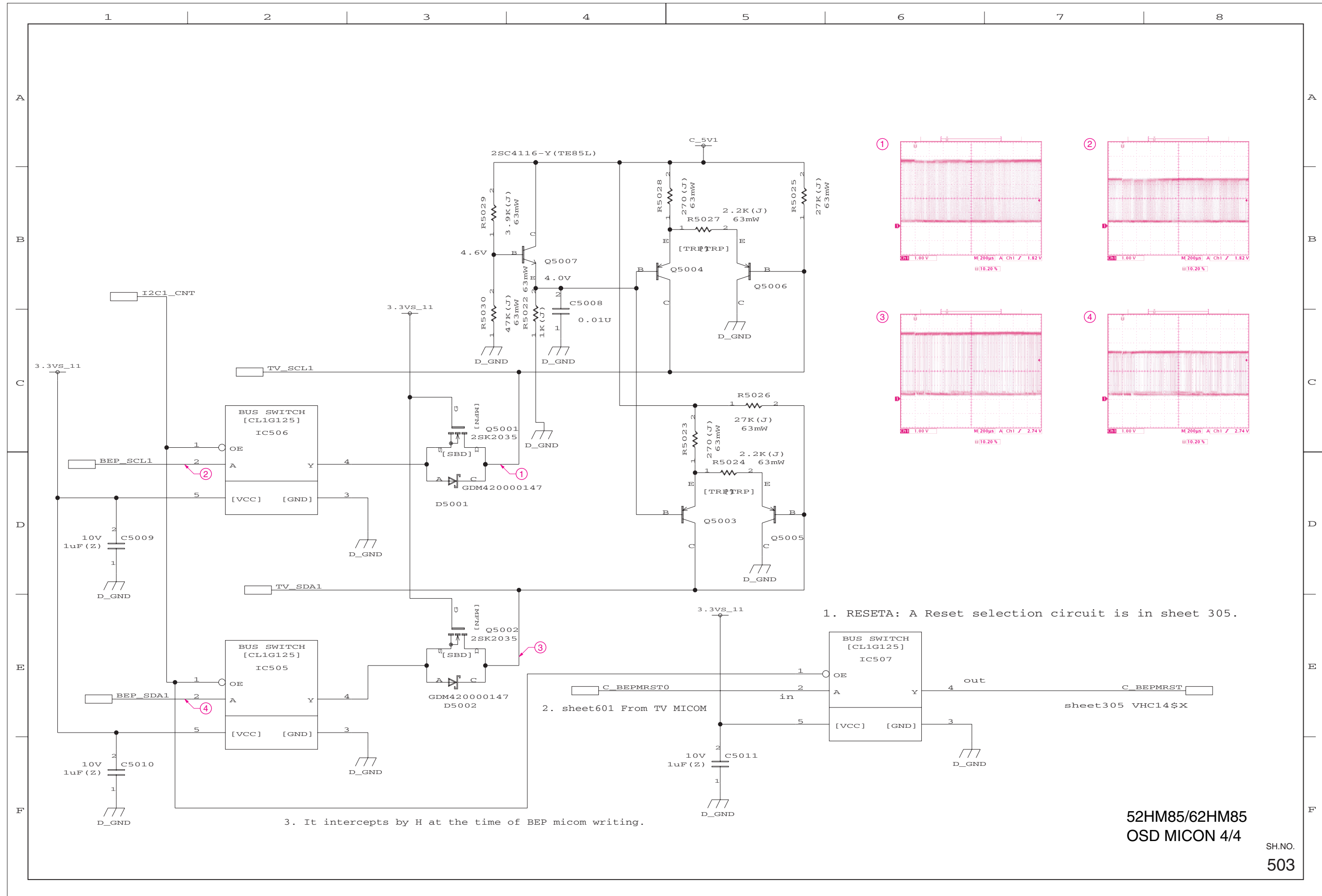

52HM85/62HM85
OSD MICON 4/4

SH.NO.
503

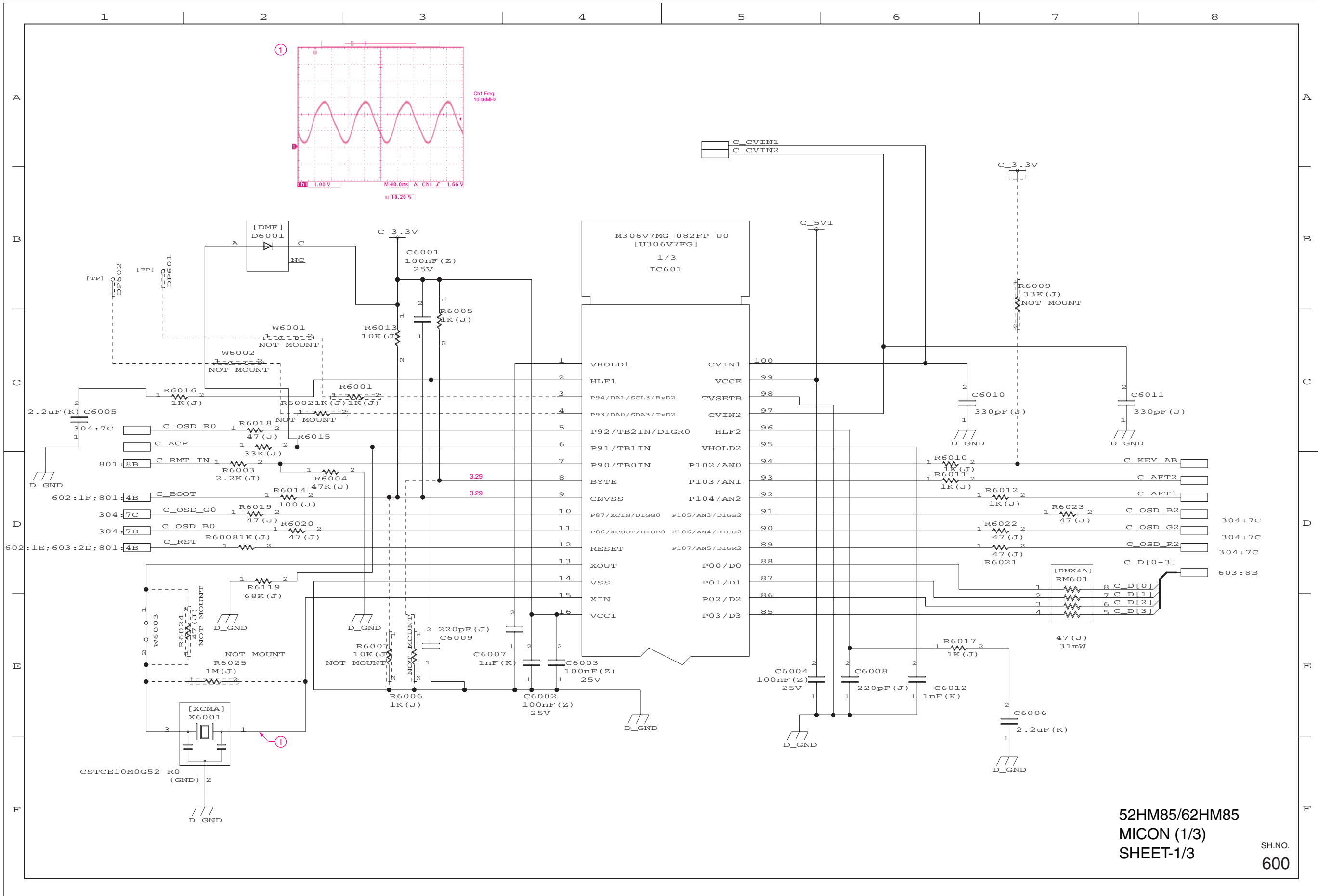

52HM85/62HM85
MICON (1/3)
SHEET-1/3

SH.NO.
600

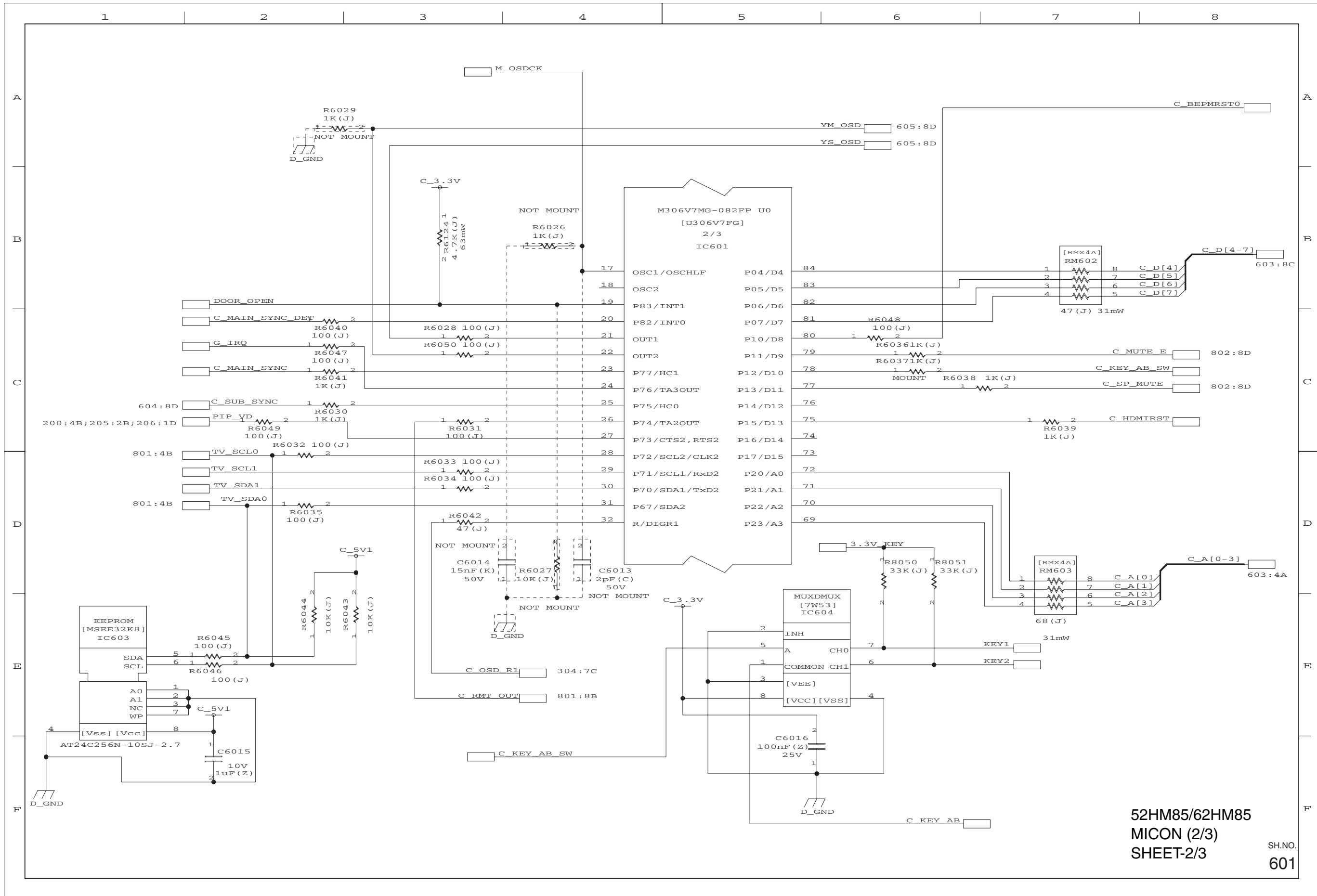

52HM85/62HM85
MICON (2/3)
SHEET-2/3

SH.NO.
601

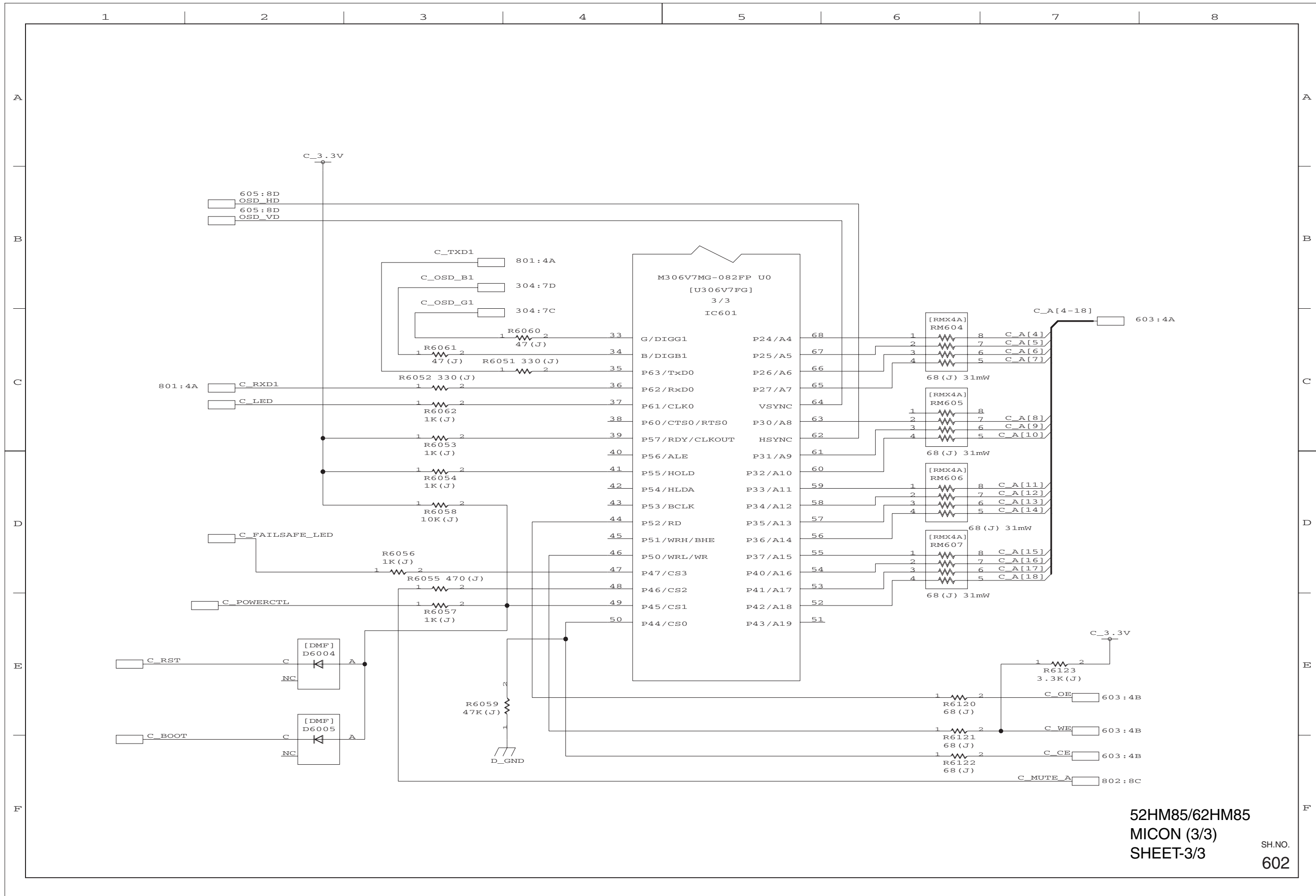

52HM85/62HM85
MICON (3/3)
SHEET-3/3

SH.NO.
602

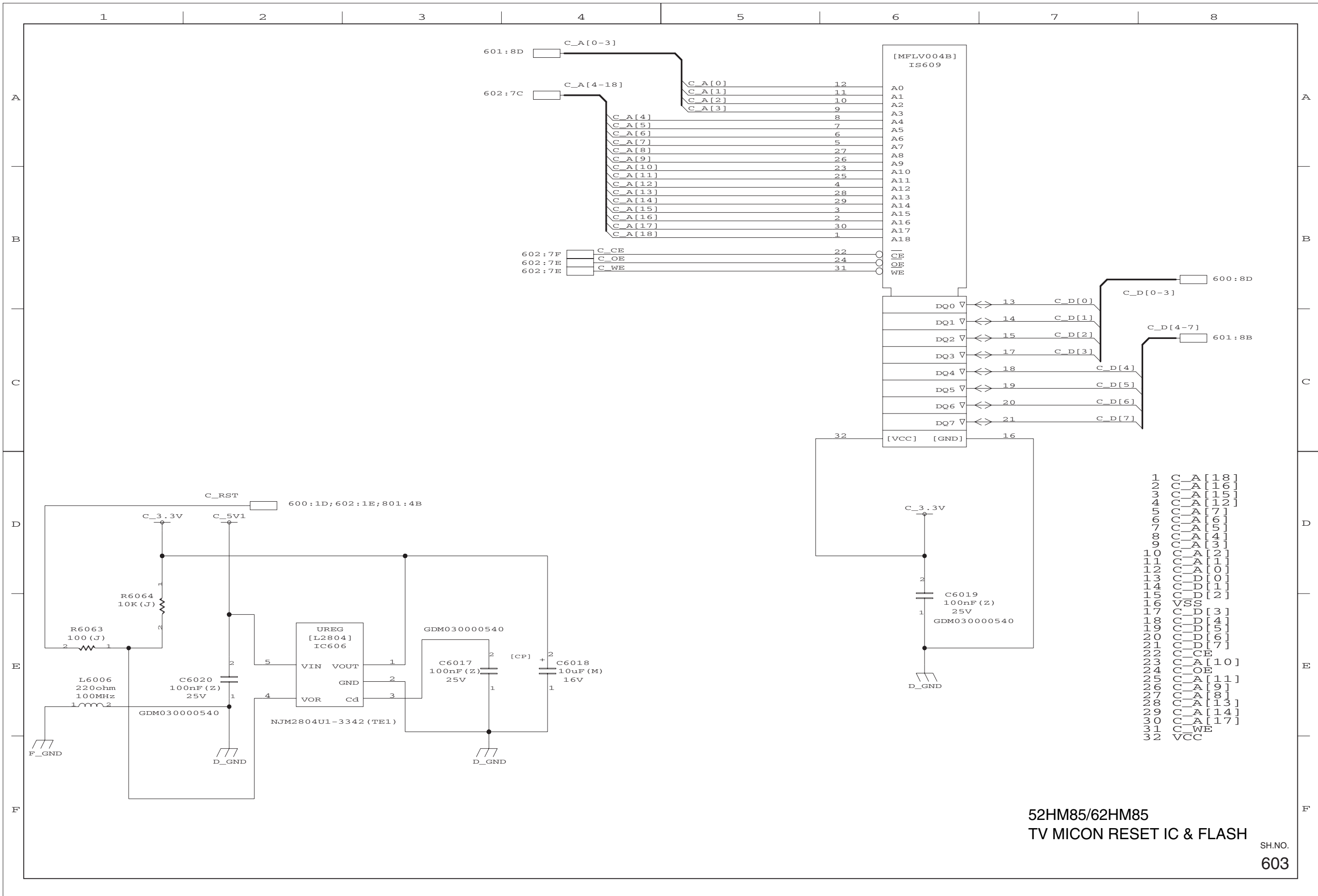

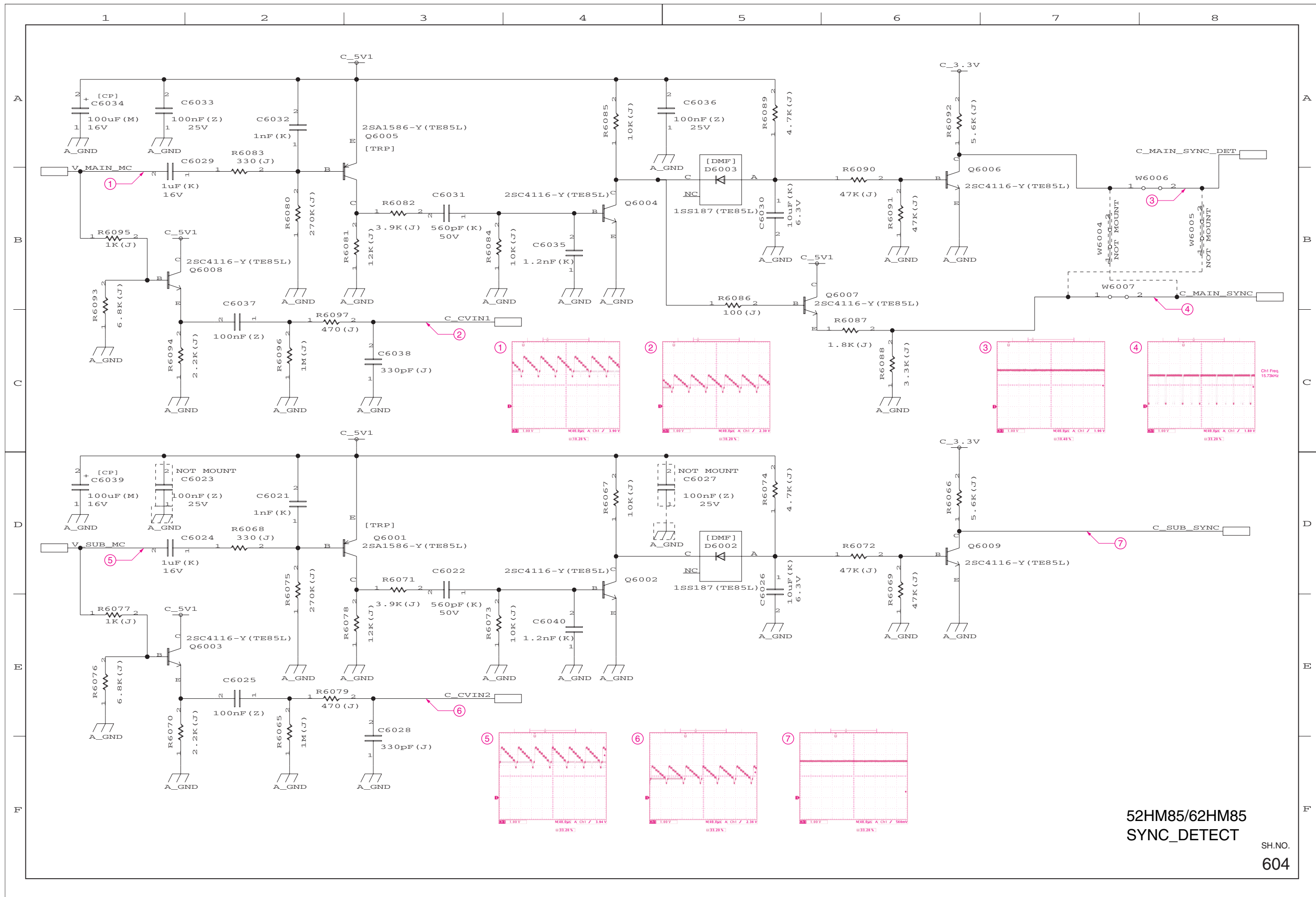

52HM85/62HM85
SYNC_DETECT

SH.NO.
604

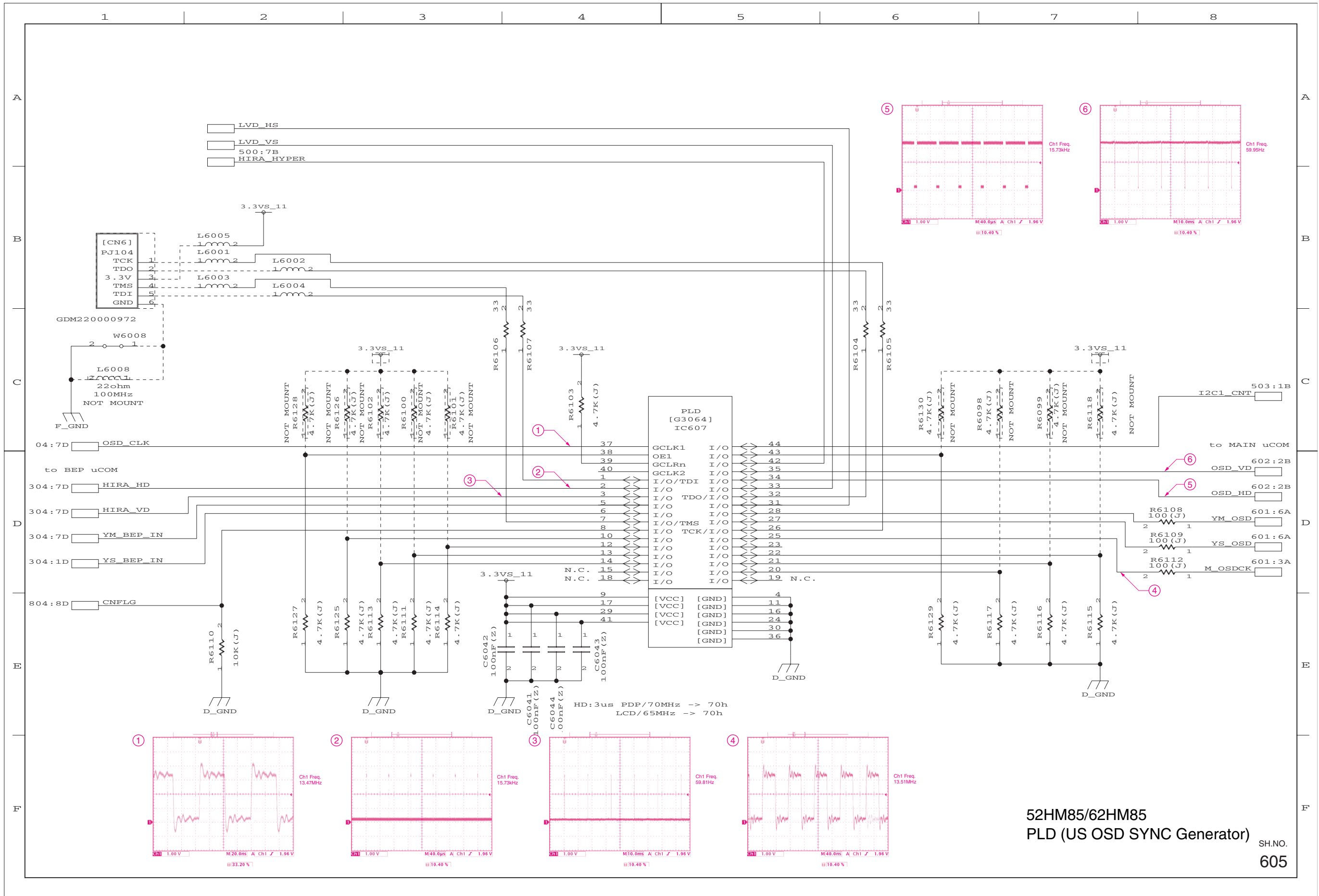

52HM85/62HM85
PLD (US OSD SYNC Generator)

SH.NO.
605

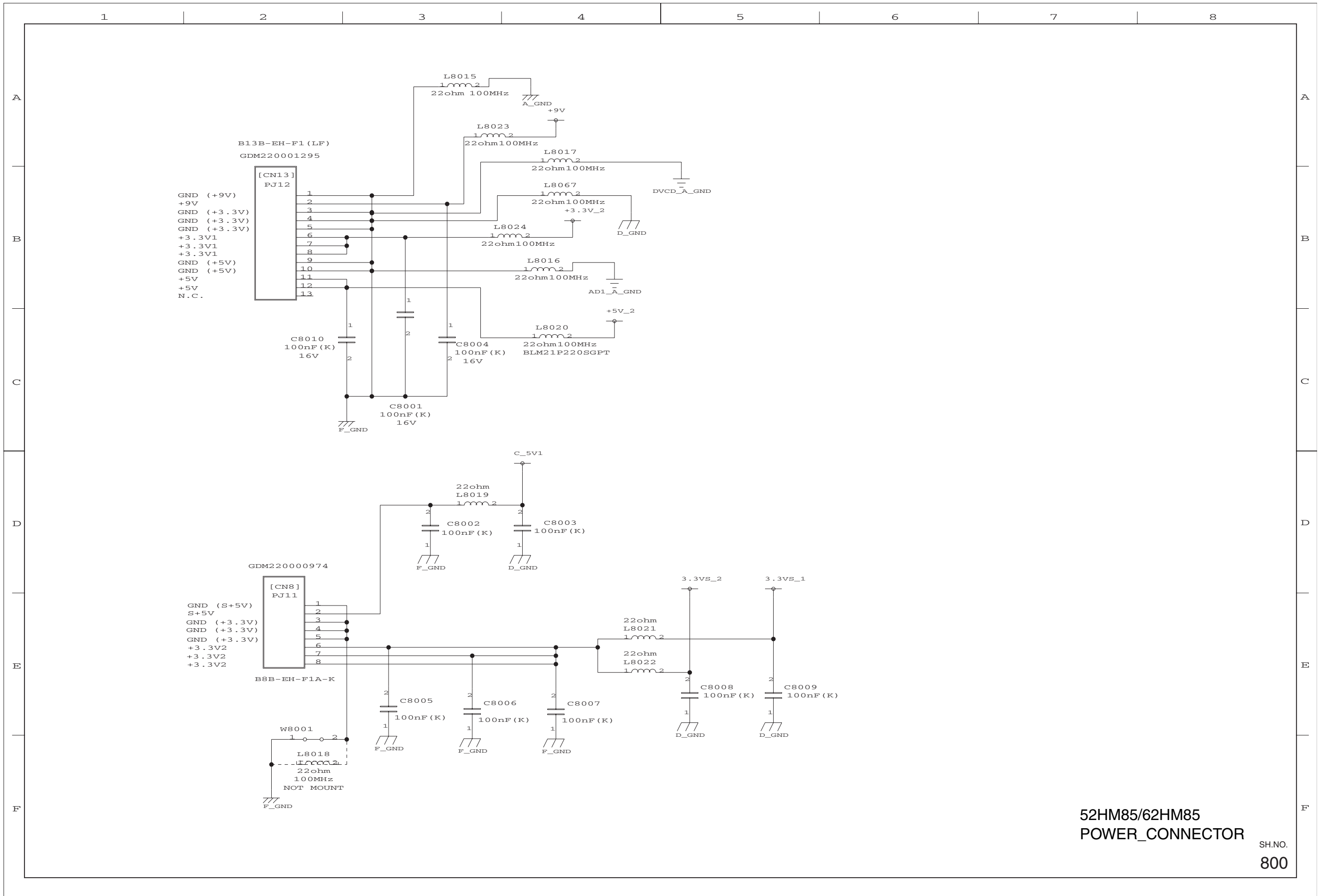

52HM85/62HM85
POWER_CONNECTOR

SH.NO.
800

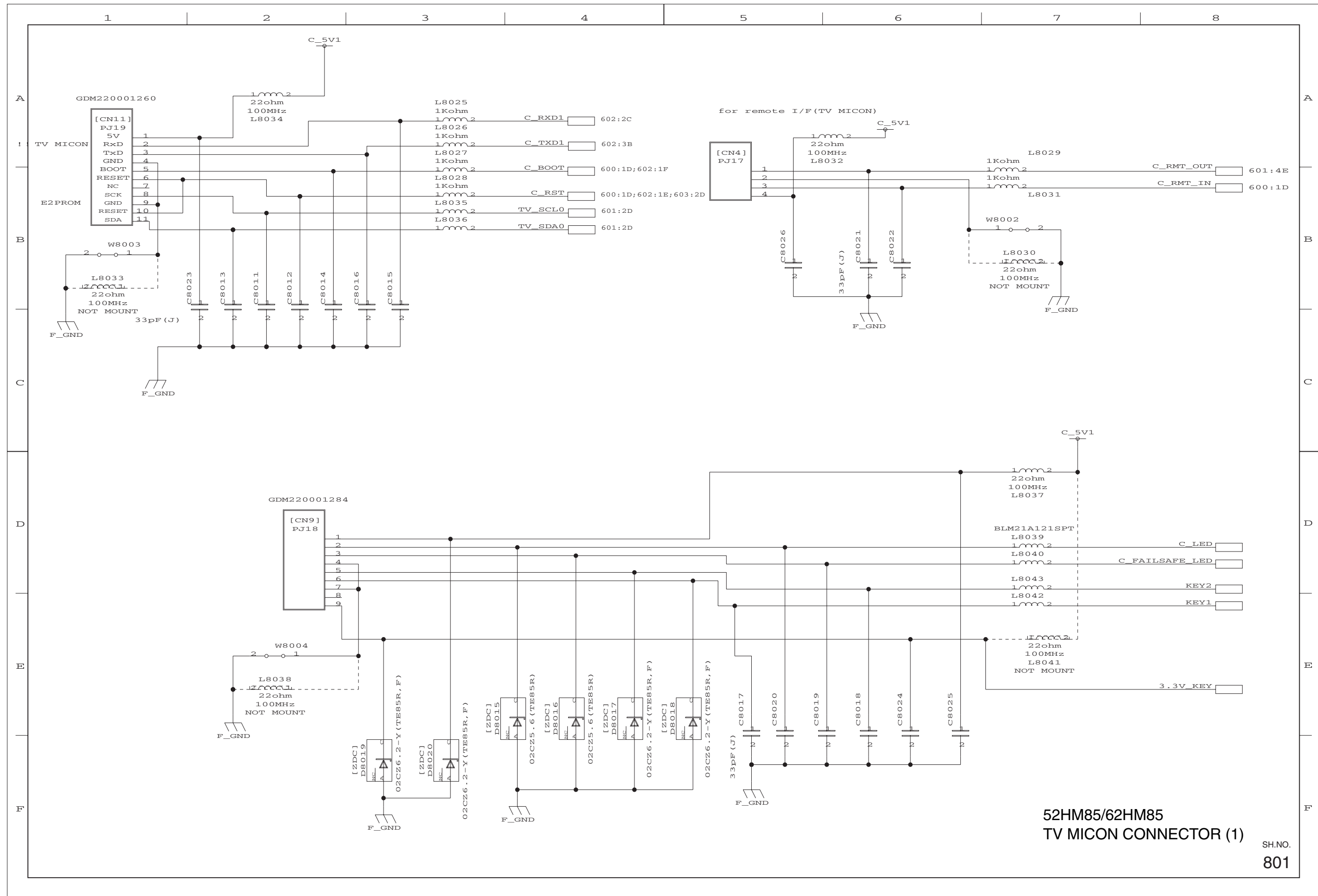

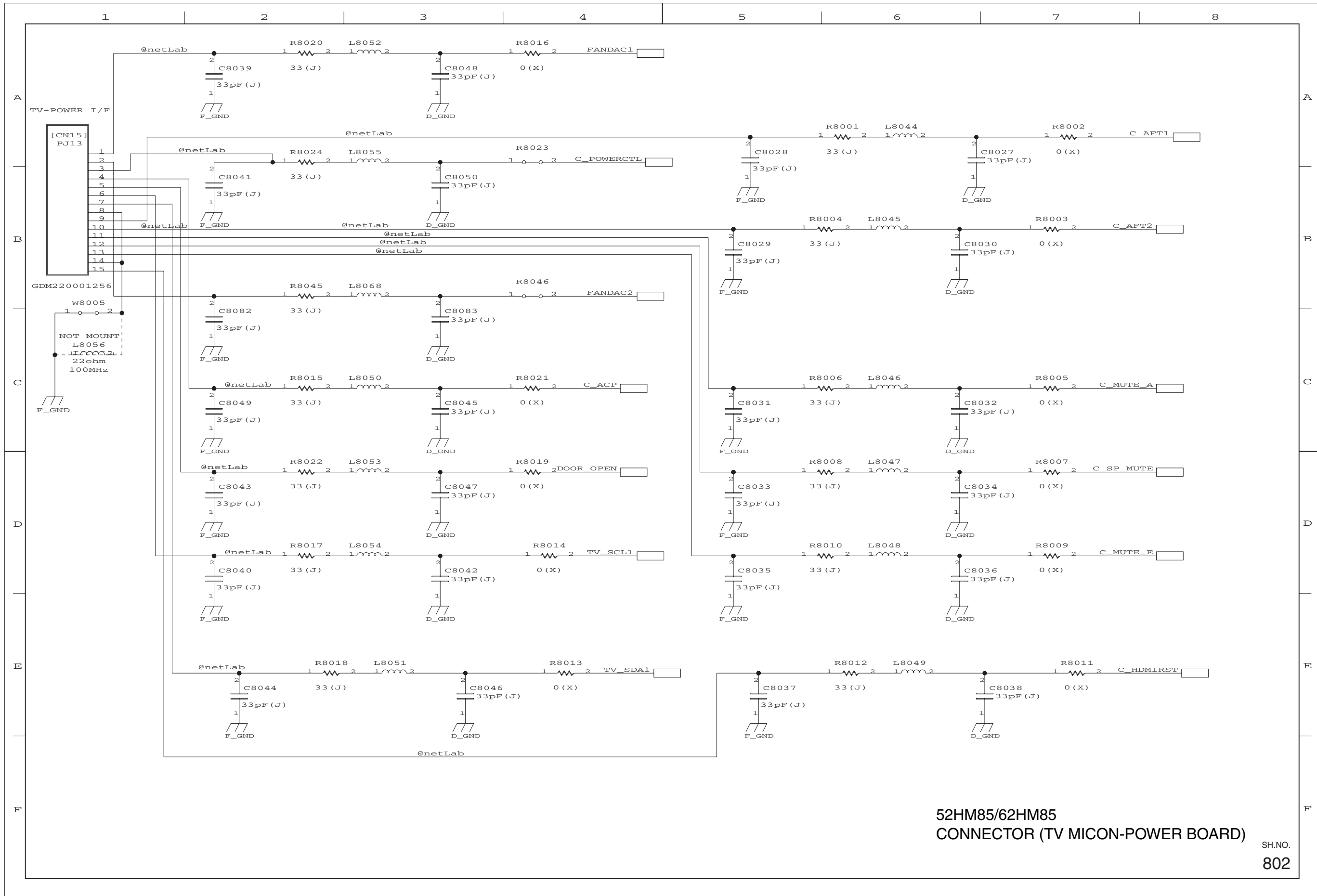

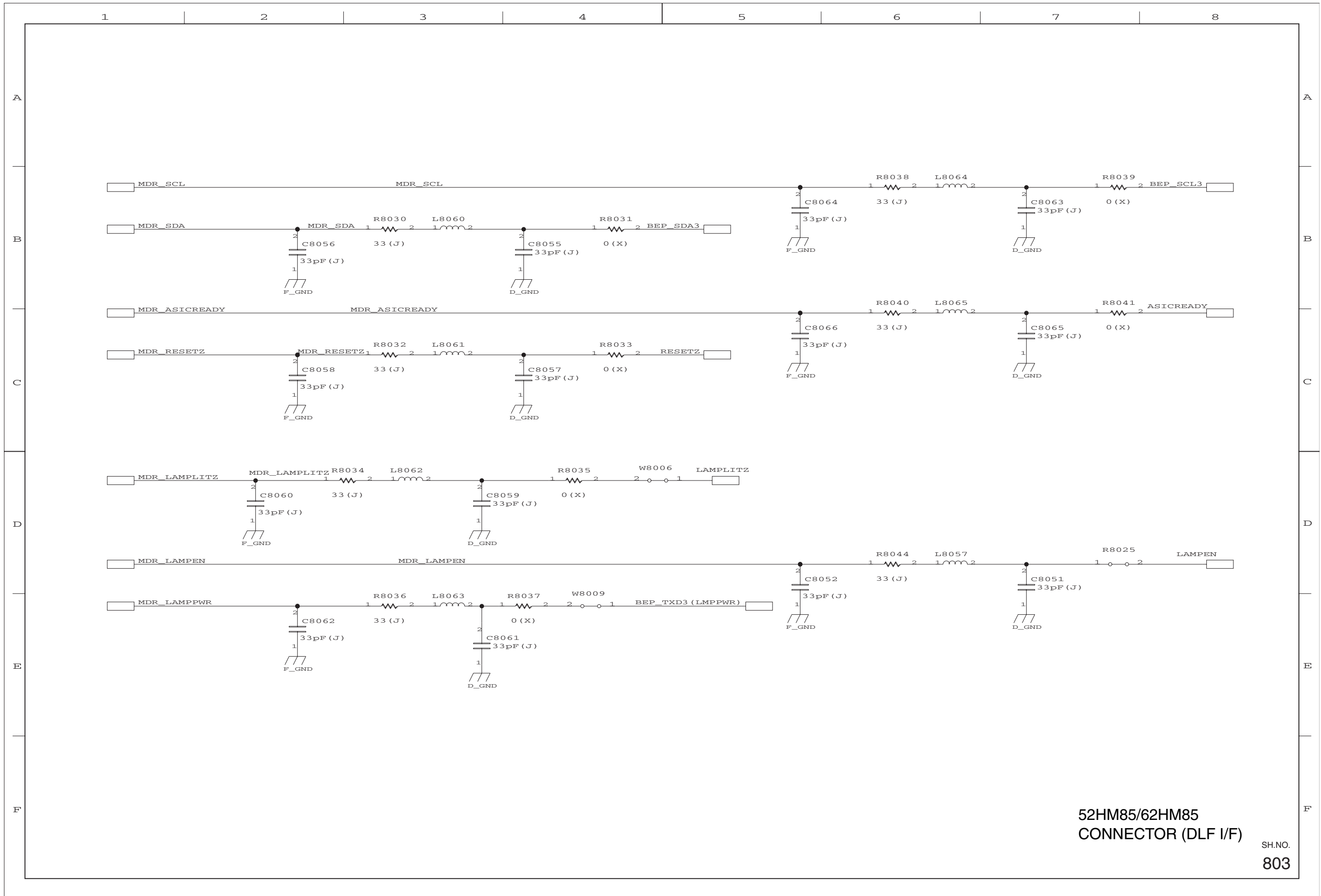

52HM85/62HM85
CONNECTOR (DLF I/F)

SH.NO.
803

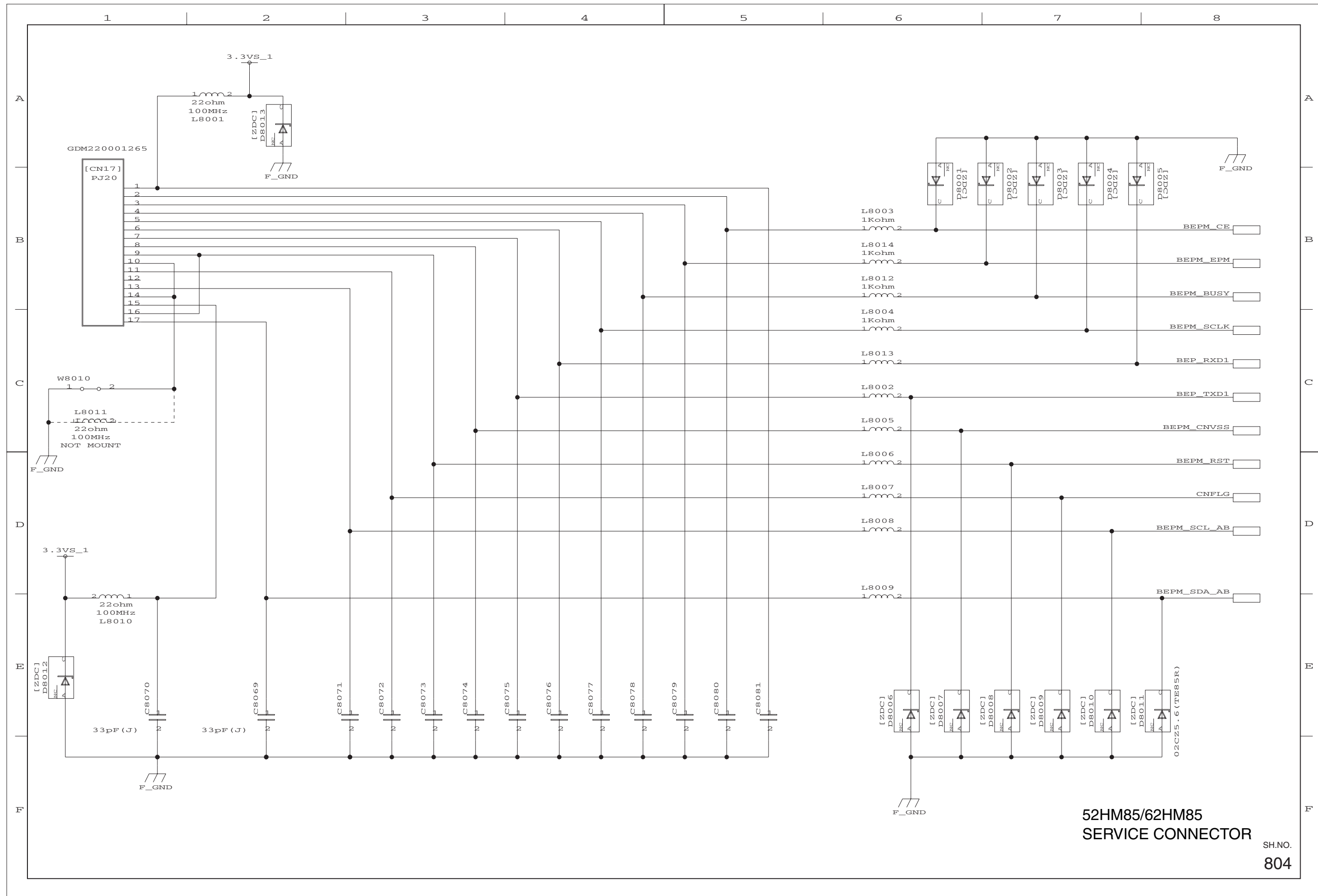

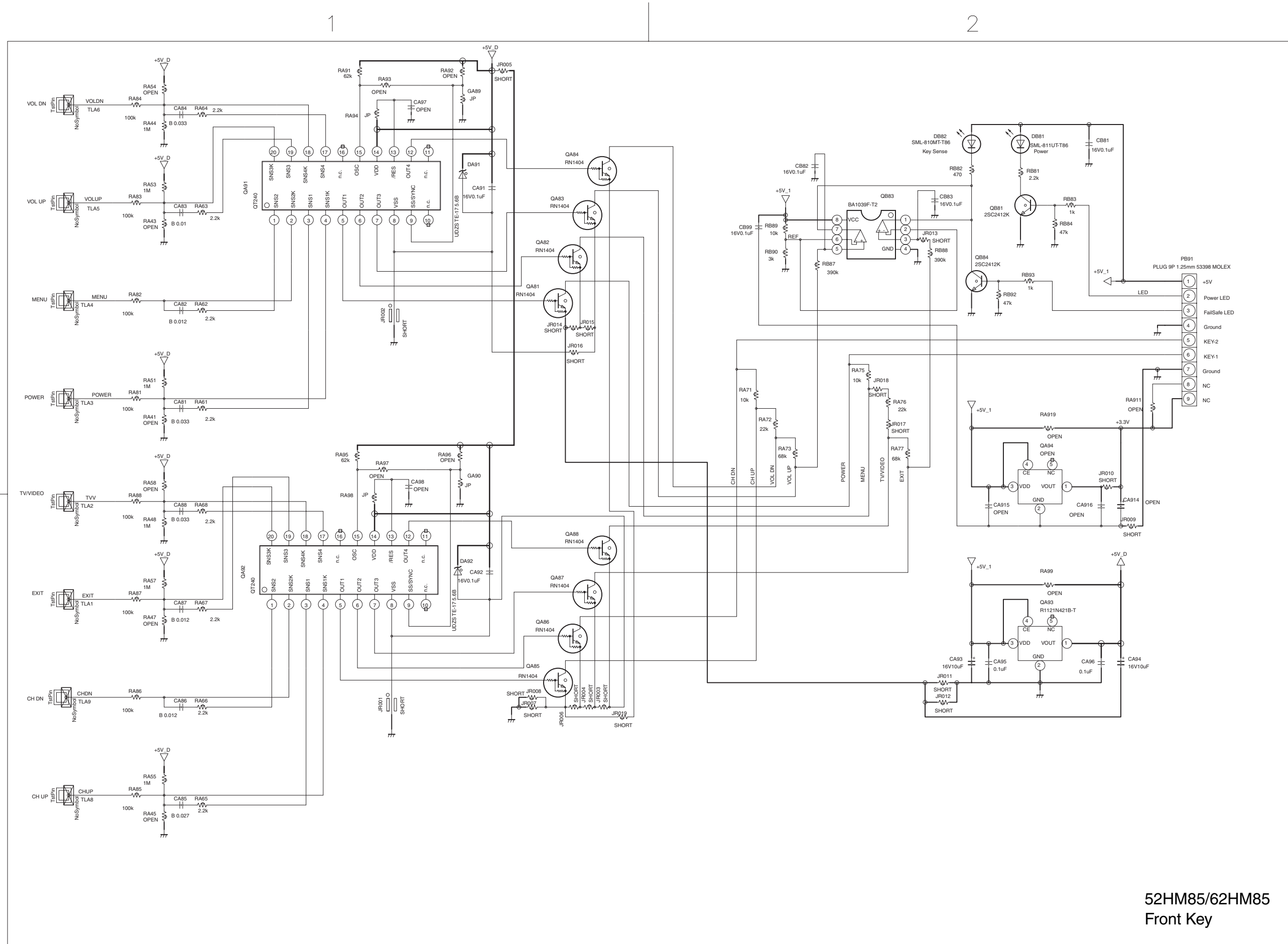

52HM85/62HM85
Front Key

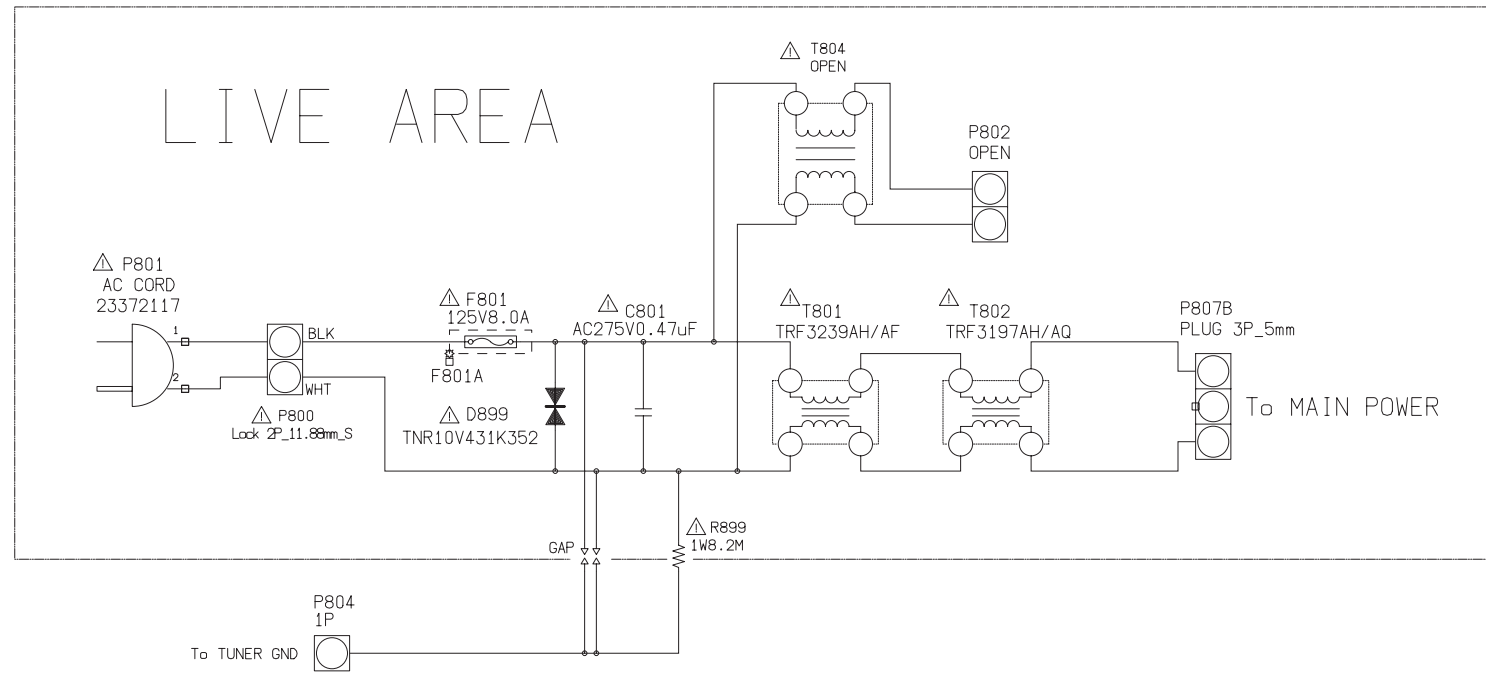

52HM85/62HM85
AC IN

TOSHIBA CORPORATION
1-1, SHIBAURA 1-CHOME, MINATO-KU, TOKYO 105-8001, JAPAN